

General Specifications

InfraSpec™ NR800 Fourier Transform Near-Infrared Analyzers

GS 12Y03A03-01E

■ Overview

The NR800 Fourier Transform Near-Infrared Analyzers offers high-resolution, high S/N (signal-to-noise) ratio, and wide wavelength scanning range measurement with its newly developed interferometer and detector. The NR800 also offers high stability, vibration resistance, and durability, inheriting features from NR500 earlier successful models. The NR800 allows online, real-time, continuous, multiple, and simultaneous measurement for properties and component concentration of various processes.

■ Features (including options)

● Newly developed interferometer and detector

Used for a variety of applications, ranging from over to combination tone.

- High resolution: Up to 4 cm^{-1} , user selectable setting
- High S/N ratio: 2250:1 (RMS, 4 cm^{-1} resolution, $4100\text{ to }4200\text{ cm}^{-1}$, 1 sec.)
- Wide wavelengths scanning range 900 to 2500 nm ($11,000\text{ to }4000\text{ cm}^{-1}$)
- Wavelength reproducibility: 0.007 cm^{-1}
- Wavelength accuracy: 0.04 cm^{-1}

● Enhanced environmental resistance, durability, and reliability

- Provides high vibration resistance by a unique design free of sliding parts
- Features a multi-channel measurement optical system free of moving parts
- Eliminates the need for a PC for continuous operation.
You need an engineering computer only for Calibration Modeling and data loading.

● Outstanding wavelength accuracy allows calibration model transport between NR800s

● Outlier detection and self-diagnostic features come as standard function



Explosion proof Model

● Various standard features and available options for optimal system configuration

- Dust-proof and drip-proof: IP53 equivalent or NEMA TYPE 3R
- Optional Explosion-proof Enclosure: FM, TIIS (*1), KOSHA
- Non-moving multi-channel measurement: Expandable to 4 channels
- Up to 12 items can be measured per stream: limited to 64 items / unit
- The optional I/O unit offers a variety of inputs/outputs:
Analogue output (up to 40 points), analogue input, and contact input/output
- Communication output: RS-422
- Fast Ethernet communication between Engineering PC and the analyzer

(*1) TIIS: The Technology Institution of Industrial Safety

InfraSpec and SPECTLAND are trademarks or registered trademarks of Yokogawa Electric Corporation.

All other company and product names mentioned in this document are trademarks or registered trademarks of their respective companies.

Please select appropriate equipment in accordance with the laws and regulations of the relevant country/region, when it is used in a location where explosive atmospheres may be present.

1. Configuration

1.1 Configuration examples

• Modbus output with sampling unit (explosion-proof, 1 measuring channel)

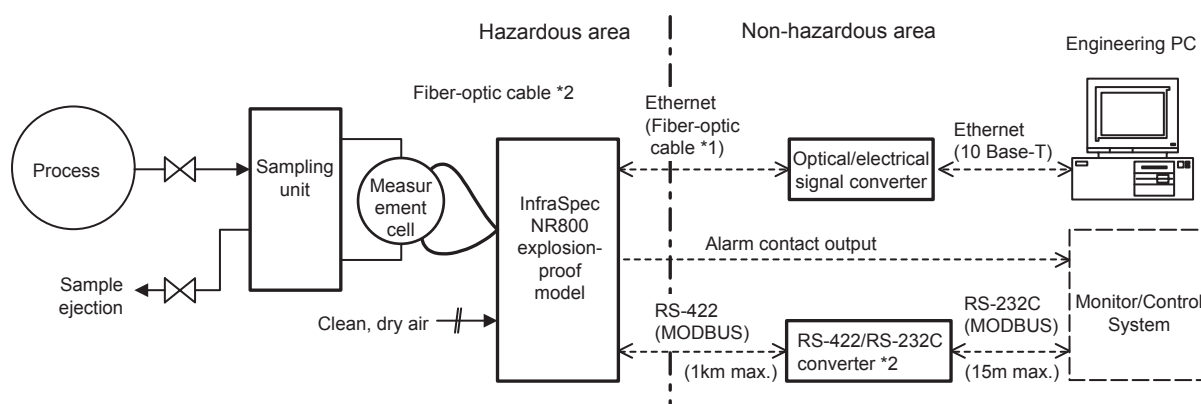

• Analogue output with sampling unit (explosion-proof, 2 measuring channels)

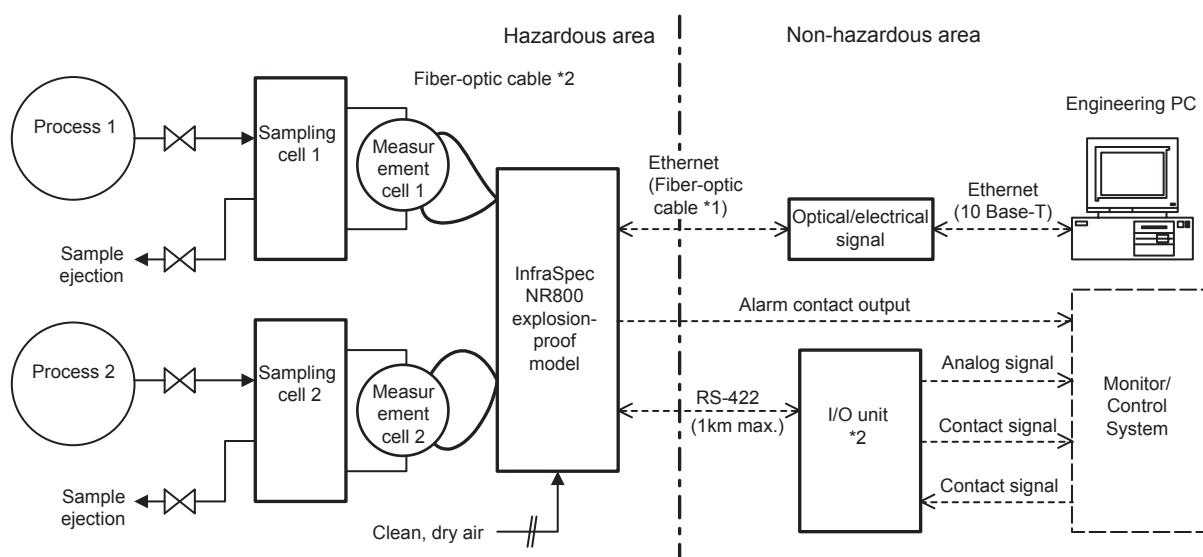

*1: Always use a special fiber-optic cable (see section "2.6 Ethernet Fiber-optic Cable") for an explosion-proof model. Electric cables cannot be used.

For a general purpose model, use specific type of cables as below, according to the length required for their installation.

- Cable length less than 40 m: Either an electric or special fiber-optic cable (see section "2.6 Ethernet Fiber-optic Cable" and "6.2 Ethernet Communication") can be used.

- Cable length of 40 m or longer: Use a special fiber-optic cable (see section "2.6 Ethernet Fiber-optic Cable" and "6.2 Ethernet Communication"). Electric cables cannot be used.

*2: Use RS-422/RS-232C converter (see section "2.5 RS-422-to-RS-232C Converter (Part Number: K9404LA or K9404LD)") or I/O unit (see section "2.2 I/O Unit", select Suffix code for explosion-proof model)

when you use RS-422 output of explosion-proof model analyzer. These units convert RS-422 output signals from analyzer to dedicated ones. These units also block the communication signal upon receiving a failure signal from the analyzer

For safety and explosion-proof integrity, follow the instruction to select specific fiber-optic cables. See section "2.4 Fiber-optic Cables for measurement" for measurement and section "2.6 Ethernet Fiber-optic Cable" for Ethernet communication.

1.2 Component, software and calibration modeling

Item		Requirement (*1)	Model	Description	Reference
1	InfraSpec NR800 analyzer	A	NR801AG	General purpose model, CSA standard	1.3, 2.1
			NR805AG	Explosion-proof model, FM certified	
			NR801JG	General purpose model, Japanese version	
			NR805JG	Explosion-proof model, TIIS certified (excluding NR805JG/K), KOSHA certified (only for NR805JG/K)	
2	I/O unit	B	NR893AG	To be used with NR801,805AG, CSA standard	1.3, 2.1
			NR893JG	To be used with NR801,805JG	
3	Measurement cell	A	NR510	Flow through cell	2.3.1
			NR512	Flow through cell with constant temperature water tube	2.3.2
			NR511	Special measurement cell	2.3.3
			FIR200	In-situ probe	2.3.4
4	Fiber-optic cable for measurement	A	NR821	Applicable wavelength range: 900 to 2100 nm, Silica, single	2.4.1
			NR822	Applicable wavelength range: 900 to 2100 nm, Silica, dual	
			NR823	Applicable wavelength range: 900 to 2500 nm, Fluoride, single	2.4.2
			NR824	Applicable wavelength range: 900 to 2500 nm, Fluoride, dual	
5	RS-422 / RS-232C converter	B	K9404LA or K9404LD	Converts the RS-422 signal from the analyzer into RS-232C.	2.5
6	Ethernet cable (*2)	B	NR895	Dedicated fiber-optic cable (*3)	2.6
			-	Electric cable, provided by user	6.2
7	Software	A	NR831	SPECTLAND2 management and maintenance software	2.7
		B	NR530	Chemometrics software	2.8
8	Sampling unit	B	J439	Yokogawa will propose an optimum unit based on sample pressure, temperature, properties, and measurement items	2.9
9	On-site guidance on calibration modeling	B	J964	On-site hands-on practice and guidance	5.1
10	Calibration Modeling	B	J965	Calibration Modeling by Yokogawa based on user-provided sample with laboratory analysis results	5.2
11	Engineering PC	A	-	Provided by user. See recommended specifications.	6.1
12	Optical / electrical signal converter for Ethernet	B	-	Converts optical signals for an Ethernet output into electrical signals for engineering PC Interface. Provided by user. See recommended specifications	6.2
13	Customer inspection	B	J963	For Instrument except following J443	-
		B	J443	For J439 Sampling unit and FIR200 In-situ probe	-
14	Equipment start-up	B	-	Start-up work for analyzers and sampling units	-

Notes *1: A: Required, B: optional

*2: An Ethernet cable is required. Choose either a special fiber-optic cable or electric cable depending on the following conditions:
For an explosion-proof model, always use a special fiber-optic cable (see section "2.6 Ethernet Fiber-optic Cable"). Electric cables cannot be used.

For a general purpose model, use specific type of cables as below, according to the length required for their installation.

- Cable length less than 40 m: Either an electric or special fiber-optic cable (see section "2.6 Ethernet Fiber-optic Cable" and "6.2 Ethernet Communication") can be used.

- Cable length of 40 m or longer: Use a special fiber-optic cable (see section "2.6 Ethernet Fiber-optic Cable" and "6.2 Ethernet Communication"). An electric cable cannot be used.

*3: If a total cable distance is longer than 20 m, an additional fiber-optic cable (see section "2.6 Ethernet Fiber-optic Cable") shall be provided by the user.

1.3 Safety standard, EMC standard

Model		I/O unit	Safety Standard	EMC standard
FT-NIR analyzer				
NR801AG, NR805AG *2	NR893AG *2		CSA C22.2 No.61010-1 (exclude NR805AG) *1 FM Class 3810 ANSI/ISA 61010-1 ANSI/ISA-82.02.02 (IEC 61010-2-031)	-
NR801JG, NR805JG (excluding NR805JG/K)	NR893JG		-	-
NR805JG/K	-		-	Korea Electromagnetic Conformity Standard

*1: • Installation category (Overvoltage category) II

This number represents the transient overvoltage condition. This also complies with the regulation on impulse withstand voltage.
"II" applies to electrical equipment whose power is supplied from fixed installations such as distribution boards.

- Pollution Degree 2

Describes how much the dielectric strength or surface resistivity is being deteriorated by adherence of solid, liquid or gas substances.
"2" applies to normal indoor atmosphere. Normally, only non-conductive pollution occurs.

*2: Install 5 A breaker in the power supply circuit

2. Component specifications (including options)

2.1 NR800 Fourier Transform Near-Infrared Analyzers

2.1.1 Hardware specifications

Principle: Fourier-transform remote measurement via fiber-optic cable
 Measurement method: Optical transmission absorption
 Measured sample: Liquid
 Classification of laser product:
 Class 1 Laser Product (IEC 60825-1:2007/2014)
 Beam source: Halogen lamp (recommended replacement interval for continuous operation: 5000 hours)
 Detector: InGaAs (indium gallium arsenide) photodiode, effective wavelength range: 900 to 2500 nm
 Number of measuring channels: 1 to 4 (non-moving)
 Housing structures: Field suitable with full hinged front cover
 Fiber-optic cable entry: Cable gland
 Fiber-optic cable connectors:
 For measurement; FC
 For Ethernet; ST

Display: LED
 Keyboard: Covered with water-proof sheeting
 Operating location requirements: See section "4. Installation Condition".
 Grounding type: Independent, 100Ω or lower
 Insulation resistance: 10 MΩ or greater (500VDC)
 Withstanding voltage:

Power Supply	Withstanding Voltage
100VAC, 115VAC	1000 VAC for 1 min.
200VAC, 230VAC	1500 VAC for 1 min.

Coating: Epoxy resin coating
 Paint colour:

Model	NR801AG, NR801JG	NR805AG, NR805JG
Flame proof enclosure	-	Lamp black (equivalent to Munsell 0.8Y 2.5/0.4)
Air regulator cover	-	Munsell 0.8Y 2.5/0.4)
Case	Frosty white (equivalent to Munsell 2.5Y8.4/1.2)	
Display panel	Lamp black (equivalent to Munsell 0.8Y 2.5/0.4)	
Wall mount bracket, Free standing rack	Deep sea moss green (equivalent to Munsell 0.6GY3.1/2.0)	

Model	NR801AG	NR801JG	NR805AG	NR805JG (excluding NR805JG/K)	NR805JG /K
Explosion proof	General purpose type (non explosion-proof)		FM *1, *2	TIIS *3	KOSHA *5
Housing structure	IP53, NEMA 3R or CSA Type 3R				
Air (purge gas) connection	-		1/4NPT (F)	Rc1/4 or 1/4NPT (F)	
Cable connection	Packing gland		3/4NPT(F)	Flame-proof packing gland or sealing fitting	
Weight (kg) *4	Without bracket		Approx. 50		
	With wall mount bracket		Approx. 55		
	Free stand rack		Approx. 85		
				Approx. 65	
				Approx. 70	
				Approx. 100	

- *1: Type X purging and explosion proof for Class I, Division 1, Groups B, C and D. Temperature Class T5.
 All wiring shall comply with the manufacture's instructions, National Electrical Code ANSI/NFPA 70 and Local Electrical Codes.
 *2: All wiring shall comply with the manufacture's instructions and Local Electrical Codes.
 *3: Ex pd II B+H2 T5 X
 All wiring shall comply with the manufacture's instructions and Local Electrical Codes.
 *4: Not including weight of the packaging materials.
 *5: KOSHA, Ex dp IIB+H2 T5
 All wiring shall comply with the manufacture's instructions and Local Electrical Codes.

2.1.2 Performance

Wavelength scanning range: 900 to 2500 nm (11000 to 4000 cm^{-1})
 Wavelength resolution: 4, 8, 16, 32, and 64 cm^{-1} (user selectable)
 Wavelength reproducibility: 0.007 cm^{-1}
 Wavelength accuracy: 0.04 cm^{-1}
 S/N ratio 2250:1 (RMS, resolution 4 cm^{-1} , 11000 to 4000 cm^{-1} , 1 sec.)

2.1.3 Inputs/Outputs (see also section "2.2 I/O Unit")

(1) Communication Interface:

Engineering PC: 1 channel (Ethernet)
 DCS / I/O unit: 2 channels (RS-422)
 1 channel for DCS (Modbus) and another for I/O unit; or 2 channels for I/O unit

(2) Contact outputs:

Specification: NC/NO selectable, 2 channels
 Rating: 0.5 A, 30 VDC or less
 Action:
 General purpose model:

NR800 analyzer power "ON/OFF"; Power fail signal

Status	DO1 Terminal Number	
	1 to 2	2 to 3
Power "off"	Short	Open
Power "on"	Open	Short

NR800 System alarm

Status	DO2 Terminal Number	
	1 to 2	2 to 3
Power "off"	Short	Open
Alarm occurred	Short	Open
Alarm not occurred	Open	Short

Explosion proof model:

NR800 System alarm

Status	Terminal Number	
	D1 to D2	D2 to D3
Power "off"	Open	Short
Alarm occurred	Open	Short
Alarm not occurred	Short	Open

Annunciator signal output

Status	Terminal Number	
	A1 to A2	A2 to A3
Power "off"	Open	Short
During purging	Open	Short
Override switch pressed *	Open	Short
After purging	Short	Open

*: Overriding
NR800 has Overriding function. Normally power supply is automatically shut off when you open the door of the pressurized explosion-proof enclosure (on the analyzer). However, Overriding function allows you to open the door of explosion-proof section without automatic power off
A switch of the overriding function is located inside the analyzer (flameproof). You can use the overriding to open the door of the explosion-proof section.
When opening the door, always make sure the ambient atmosphere is not hazardous. Use gas sensors to detect and eliminate all hazards.

2.1.4 Operating modes *1

Basic operating mode and description		Channel operating mode	
		No.	Auto/Manual.*3
Maintenance *2	Spectrum analysis of a reference sample, equipment maintenance	-	-
Run	On-line measurement (allows spectrum analysis on selected channels)	1	AUTO
			MANUAL
		2	AUTO
			MANUAL
		3	AUTO
			MANUAL
		4	AUTO
			MANUAL

Notes*1: When the power is turned on, the analyzer starts according to a predefined operating mode.

*2: Can perform spectrum analysis (not continuous measurement).

*3: Auto: Performs continuous measurement
Manual: Can perform spectrum analysis (not continuous measurement).

2.1.5 Changing and Setting Operating Mode

Some operations are prohibited depending on the user level.

User level	Abbreviation	Description	Changing/setting mode
User A	UA	For operator	Unauthorized
User B	UB	For equipment supervisor	Authorized
User C	UC	For maintenance	Authorized

- A user level can be switched on the front console panel of the analyzer or from SPECTLAND2 screen of an engineering PC.
- A password is required to switch levels from UA to UB and switch from UA or UB to UC.

2.1.6 Sample Measurement

(1) Continuous measurement

Number of measuring channels:
1 to 4 (Specification is required.)

Data updating period:
4 seconds or longer (depending on the number of averaging and measuring channels, as well as measurement items)

Number of measurement items:
Up to 12 per channel (48 max. per analyzer)

Number of outlier detection items:
Up to 12 per channel (48 max. per analyzer)

Separate maintenance is available for each channel (except for common hardware).

(2) Stream switching by input signal (intermittent measurement)

Calibration model set for the each channel can be changed by external input signal. This function is used for multi-stream application or multi sample application.

Stream switching

Number of streams to switch: Up to 16

Switching patterns:

See "Table 1 Stream numbers assignable to measuring channels corresponding to switching patterns".

Contact inputs:

See section "2.2 I/O Unit"

RS-422 communication:

See section "2.1.8 MODBUS"

Data updating period:

8 seconds or longer (depending on the switching pattern, numbers of averaging and measuring channels, and stream configuration)

Number of measurement items:
Up to 12 per stream (64 max. per analyzer)

Number of outlier detection items:
Up to 12 per stream (64 max. per analyzer)

Separate maintenance is available for each channel (except for common hardware).

Input signals and measurement computation sequence

Stream identification:

Used to identify the selected sample. The analyzer will choose a calibration model set to suite for the relevant stream based on this signal.

Measurement enabled (valid sample):

When closed, the analyzer performs measurement using the calibration model specified by the sample identification signal above.

Schematic timing chart of measurement and computation sequence (e.g. 2 streams)

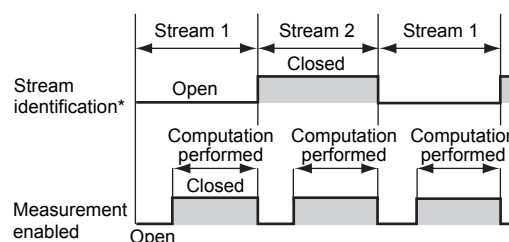

Notes (*) A stream number is defined by a combination of open/closed states of an identification contact signal.

Table 1 Stream numbers assignable to measuring channels corresponding to switching patterns

Stream switch		Measuring channel No. *3				Total streams	Applicable channel No.
Case	Pattern No.	1	2	3	4		
None	0	1	2	3	4	4 max	1 to 4
Stream switching per channel *2	1 *1	1 to (17-N)	18-N	19-N	20-N	16 max	1 to 4
	2	1 to 8	9 to 16	None	None	16 max	1 to 2
	3	1 to 4	5 to 8	9 to 12	13 to 16	16 max	1 to 4

Notes

*1: N: Maximum number of measuring channels included within the analyzer.

*2: The stream number for a measuring channel that does not switch paths must be the smallest number in the relevant column.

*3: Measuring channel numbers that equal the number of measuring channels included within the analyzer or smaller are valid.

2.1.7 Console Panel

(1) Display items

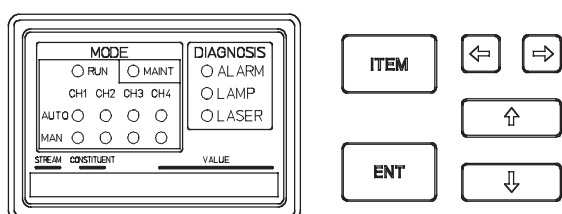

Operating mode LEDs (MODE)

The following LEDs indicate the current basic operating mode:

RUN: Lit when in the Run mode.

MAINT: Lit when in the Maintenance mode.

The operating modes of each channel are displayed by LEDs when in the Run mode.

Two LEDs are provided for each channel, amounting to a total of 8 LEDs.

AUTO: Lit when in the Auto mode.

MAN: Lit when in the Manual mode.

Self-diagnosis LEDs (DIAGNOSIS)

ALARM: Lit when an alarm occurs.

LAMP: Lit when a lamp has burned out or after a time period defined by the service life setting elapses.

LASER: Lit when the laser has burned out or after a time period defined by the service life setting elapses.

LED display (16 digits, STREAM/CONSTITUENT/VALUE)

The content depends on the operating status or operation.

Operation keys

The following six keys are provided:

ITEM: Used to change items.

ENT: Used to confirm the entry.

Arrow keys: Used to move the cursor or change display.

(2) Analyzer behavior for each basic operating mode

Maintenance mode

Basic operating mode LEDs:

Only MAINT lights up.

Channel operating mode LEDs:

Lit in accordance with each setting.

Self-diagnosis LEDs:

Lit in accordance with the results of self-diagnosis.

LED display:

The display depends on the operating status.

Run mode

Basic operating mode LEDs:

Only RUN lights up.

Channel operating mode LEDs:

Lit in accordance with each setting.

Self-diagnosis LEDs:

Lit in accordance with the results of self-diagnosis.

LED display:

The display depends on the operating status.

2.1.8 MODBUS

(1) Communication specifications

Item	Specification
Communication standard*	RS-422 or RS-232C (a converter is required)
Start bit	1
Number of data bits	7 (ASCII mode) or 8 (binary mode)
Parity bit	1
Stop bit	1
Communication speed	4800, 9600 or 19200 (selectable)
Error detection	Odd number parity, Even number Parity or none (selectable)

*: Only RS-232C can be used in NR805*G explosion-proof type.
See section "1.2 Component, software and calibration modeling" and "2.5 RS-422-to-RS-232C Converter (Part Number: K9404LA or K9404LD)"

(2) Serial communication

Item	ASCII mode	RTU mode
Number of data bits	7 (ASCII)	8 (binary)
Message starting character	Colon ":"	None
Message ending character	Carriage return/Line feed "<CR><LF>"	None
Error detection	LRC (Logical Redundancy Check)	CRC-16 (Cyclic Redundancy Check)
Inter-character time out	None	100msec

(3) Support function in the MODBUS protocol

Function No.	Description
01	Reads the ON/OFF status of coils.
02	Reads the ON/OFF status of input relays.
03	Reads the current value of holding registers.
04	Reads the current value of input registers.
05	Forcibly changes the status of a coil.
06	Write a value to a holding register.
08	Loop-back test Sends back the same message as the command message.

(4) Recommended value of master side

Item	Recommended value
Transmission speed (bps)	4800/9600/19200
Time monitor of Inter-character gap	1000ms
No reply time	2 sec.
Number of transmission retries	5 times
Communication Recovery Period	30 sec.

2.1.9 Other Functions

(1) Baseline compensation: Up to 10 points

(2) Output of the result compensated using analogue inputs

The following operation result can be output.

Compensation operation processing:

$$P2 = C1 * P1 + C0 + D$$

$$D = An^2 * D2 + An * D1 + D0$$

An: Analogue input (n: 4 or less)

P1: Measurement value before the compensation

P2: Measurement value after the compensation

D0, D1, D2, C0, C1: Coefficient

(3) Output smoothing

Simple moving average (Up to 10 points)

Exponential moving average

(4) On-line measurement spectra saving

2.1.10 Model and Suffix Codes

(1) NR801AG, General purpose model

[Style: S2]

Model	Suffix Code	Option Code	Description
NR801AG	NR800 FT-NIR Analyzer, General Purpose model
Language	-E	English
Power supply	1	100 V AC ±10%, 50/60 Hz
	3	115 V AC ±10%, 50/60 Hz
	4	200 V AC ±10%, 50/60 Hz
	6	230 V AC ±10%, 50/60 Hz
-	-N	Always "-N"
-	-N	Always "-N"
Number of measuring channels	-S1	1 channel
	-M1	Expandable to 4 channels, comes with 1 channel
	-M2	Expandable to 4 channels, comes with 2 channels
	-M3	Expandable to 4 channels, comes with 3 channels
	-M4	4 channels
Wavelength scanning range	W1	900 to 2100 nm
	W2	900 to 2500 nm
Fiber-optic cable	-1	Single cable
	-2	Dual cable
-	-00	Always "-00"
Ethernet output cable	1	Electric cable, only for general purpose model and less than 40 m
	2	Fiber-optic cable
Mounting	A	Without brackets
	B	With wall-mounting brackets
	C	With free standing rack
-	-N	Always "-N"
-	-N	Always "-N"
-	-0	Always "-0"
-	0	Always "0"
Option	/SS	With stream switch input function

(2) NR805AG, Type X purged and FM approved explosion-proof model

[Style: S2]

Model	Suffix Code	Option Code	Description
NR805AG	NR800 FT-NIR Analyzer, Explosion proof model, FM approved version
Language	-E	English
Power supply	1	100 V AC \pm 10%, 50/60 Hz
	3	115 V AC \pm 10%, 50/60 Hz
	4	200 V AC \pm 10%, 50/60 Hz
	6	230 V AC \pm 10%, 50/60 Hz
-	-N	Always "-N"
-	-N	Always "-N"
Number of measuring channels	-S1	1 channel
	-M1	Expandable to 4 channels, comes with 1 channel
	-M2	Expandable to 4 channels, comes with 2 channels
	-M3 -M4	Expandable to 4 channels, comes with 3 channels 4 channels
Wavelength scanning range	W1	900 to 2100 nm
	W2	900 to 2500 nm
Fiber-optic cable	-1	Single cable
	-2	Dual cable
-	-00	Always "-00"
Ethernet output cable	2	Fiber-optic cable
Mounting	A	Without brackets
	B	With wall-mounting brackets
	C	With free standing rack
-	-N	Always "-N"
-	-N	Always "-N"
Cable entrance	-2	Female 3/4NPT
Purge air connection	2	Female 1/4NPT
Option		/SS	With stream switch input function

(3) NR801JG, General purpose model

[Style: S2]

Model	Suffix Code	Option Code	Description
NR801JG	NR800 FT-NIR Analyzer, General Purpose model
Language	-E -J	English Japanese
Power supply	1 3 4 6	100 V AC ±10%, 50/60 Hz 115 V AC ±10%, 50/60 Hz 200 V AC ±10%, 50/60 Hz 230 V AC ±10%, 50/60 Hz
-	-N	Always "-N"
-	-N	Always "-N"
Number of measuring channels	-S1 -M1 -M2 -M3 -M4	1 channel Expandable to 4 channels, comes with 1 channel Expandable to 4 channels, comes with 2 channels Expandable to 4 channels, comes with 3 channels 4 channels
Wavelength scanning range	W1 W2	900 to 2100 nm 900 to 2500 nm
Fiber-optic cable	-1 -2	Single cable Dual cable
-	-00	Always "-00"
Ethernet output cable	1 2	Electric cable, only for general purpose model and less than 40 m Fiber-optic cable
Mounting	A B C	Without brackets With wall-mounting brackets With free standing rack
-	-N	Always "-N"
-	-N	Always "-N"
-	-0	Always "-0"
-	0	Always "0"
Option		/SS	With stream switch input function

(4) NR805JG, TIIS approved explosion-proof model *1

[Style: S2]

Model	Suffix Code	Option Code	Description
NR805JG	NR800 FT-NIR Analyzer, Explosion-proof model, TIIS approved *1
Language	-E -J	English Japanese *1
Power supply	1 3 4 6	100 V AC ±10%, 50/60 Hz 115 V AC ±10%, 50/60 Hz 200 V AC ±10%, 50/60 Hz 230 V AC ±10%, 50/60 Hz
-	-N	Always "-N"
-	-N	Always "-N"
Number of measuring channels	-S1 -M1 -M2 -M3 -M4	1 channel Expandable to 4 channels, comes with 1 channel Expandable to 4 channels, comes with 2 channels Expandable to 4 channels, comes with 3 channels 4 channels
Wavelength scanning range	W1 W2	900 to 2100 nm 900 to 2500 nm
Fiber-optic cable	-1 -2	Single cable Dual cable
-	-00	Always "-00"
Ethernet output cable	2	Fiber-optic cable
Mounting	A B C	Without brackets With wall-mounting brackets With free standing rack
-	-N	Always "-N"
-	-N	Always "-N"
Cable entrance	-1 -2 -3 -4	Metal conduit (G3/4) Metal conduit (3/4NPT) Flameproof packing (G3/4) Flameproof packing (3/4NPT)
Purge air connection	1 2	Female Rc1/4 Female 1/4 NPT
Option		/SS /K	With stream switch input function KOSHA approved explosion proof model *1

*1: "TIIS" approval is not applicable when option code "/K" is selected. "Japanese" can not be selected with option code "/K."

2.1.11 External dimensions

(1) General purpose model (NR801*G type)

- Without brackets (Suffix code: A)

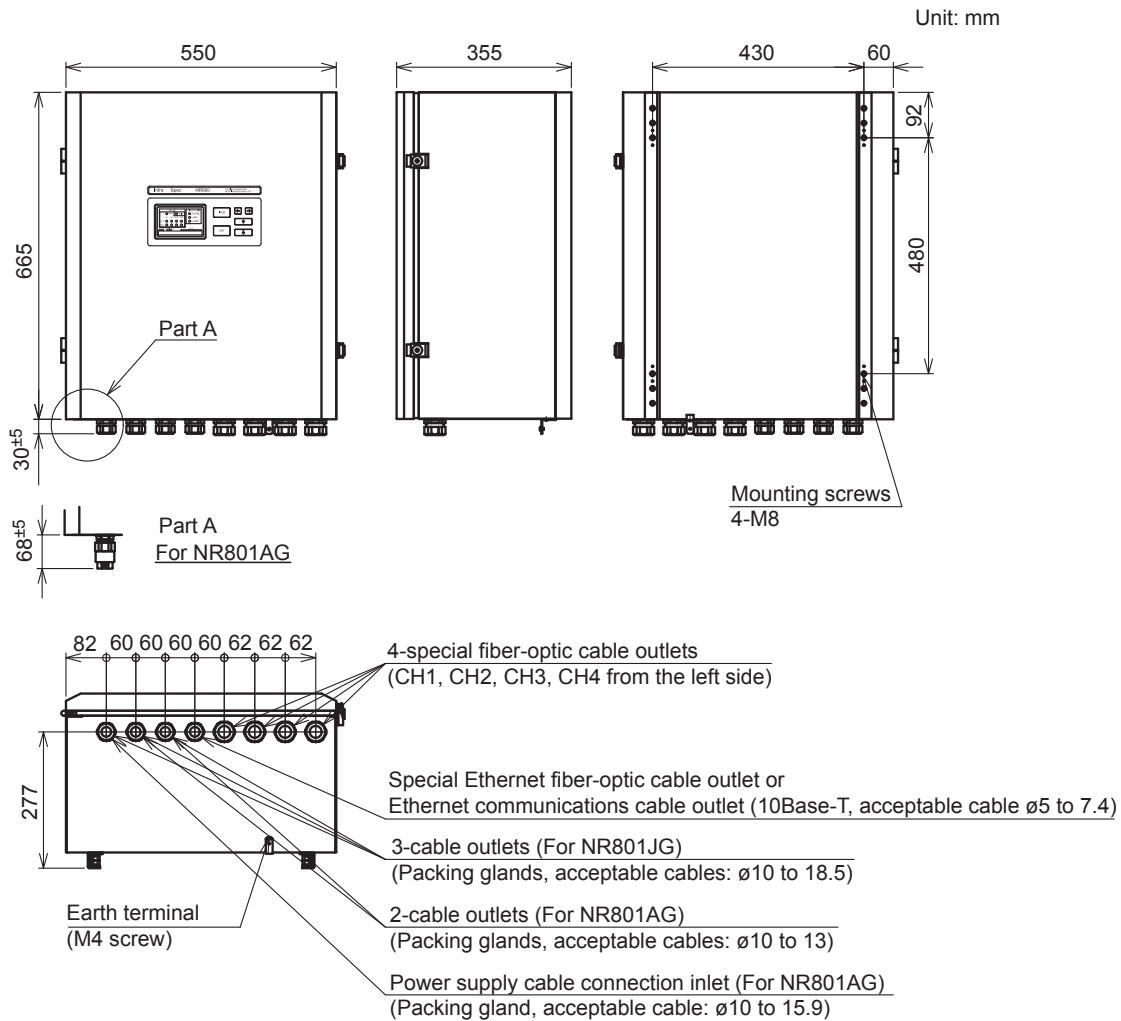

Note: The wall shall be designed to withstand four times the weight of NR800.

• Wall-mounting model (Suffix code: B)

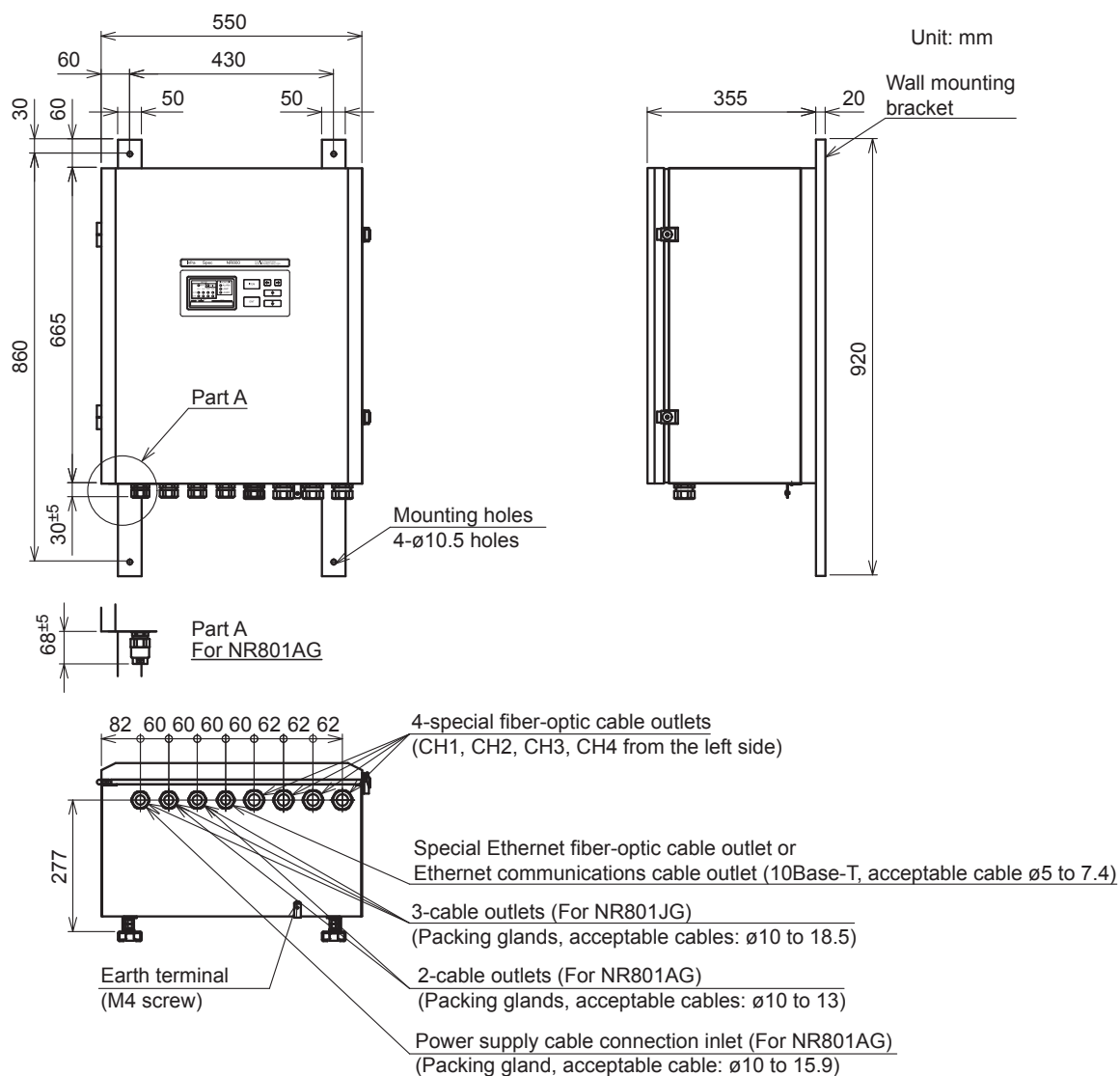

Note: The wall shall be designed to withstand four times the weight of the NR800.

- Free standing rack model (Suffix code: C)

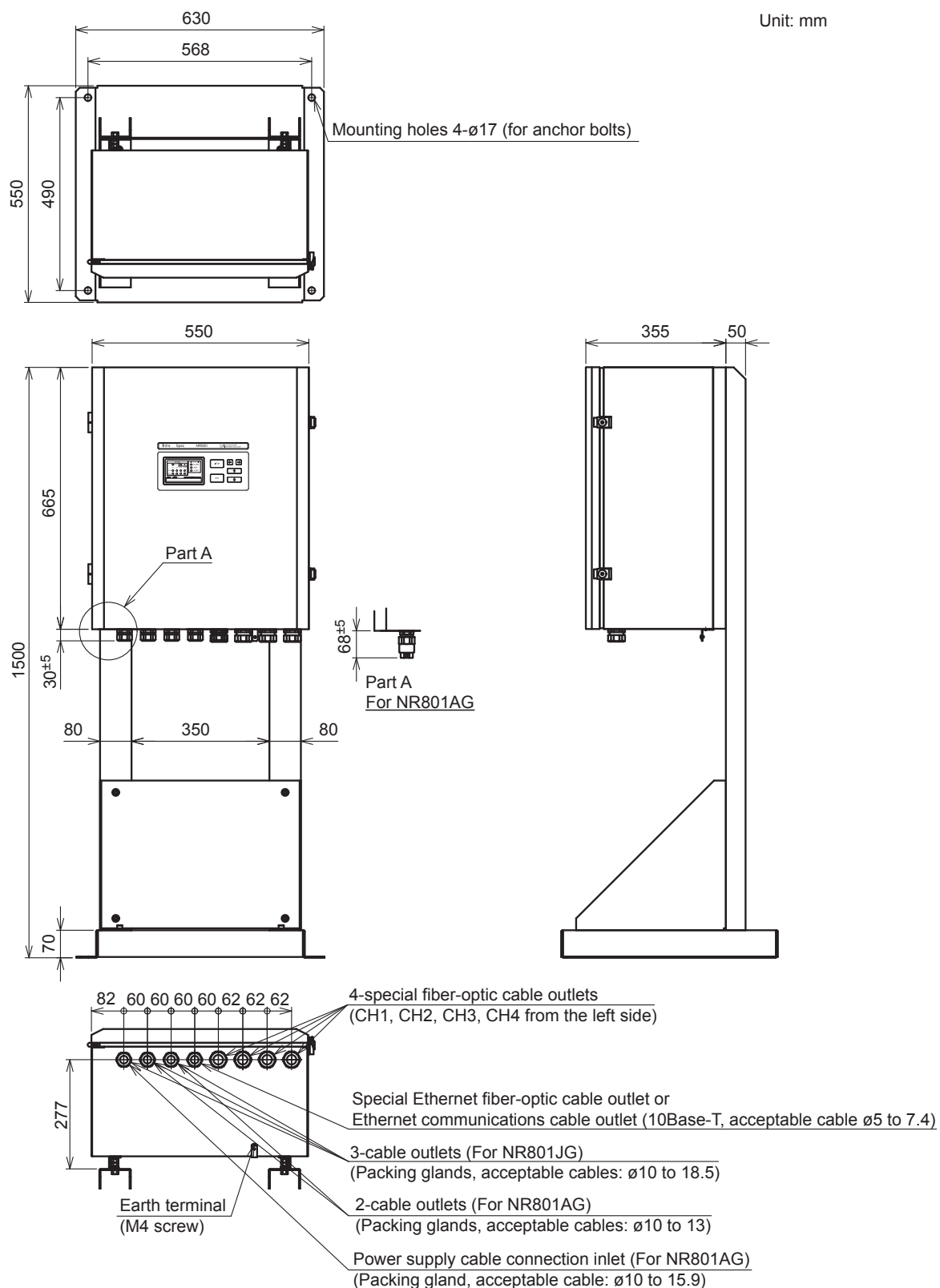

(2) Explosion-proof model (NR805*G type)

- Without brackets (Suffix code: A)

Unit: mm

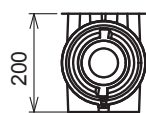
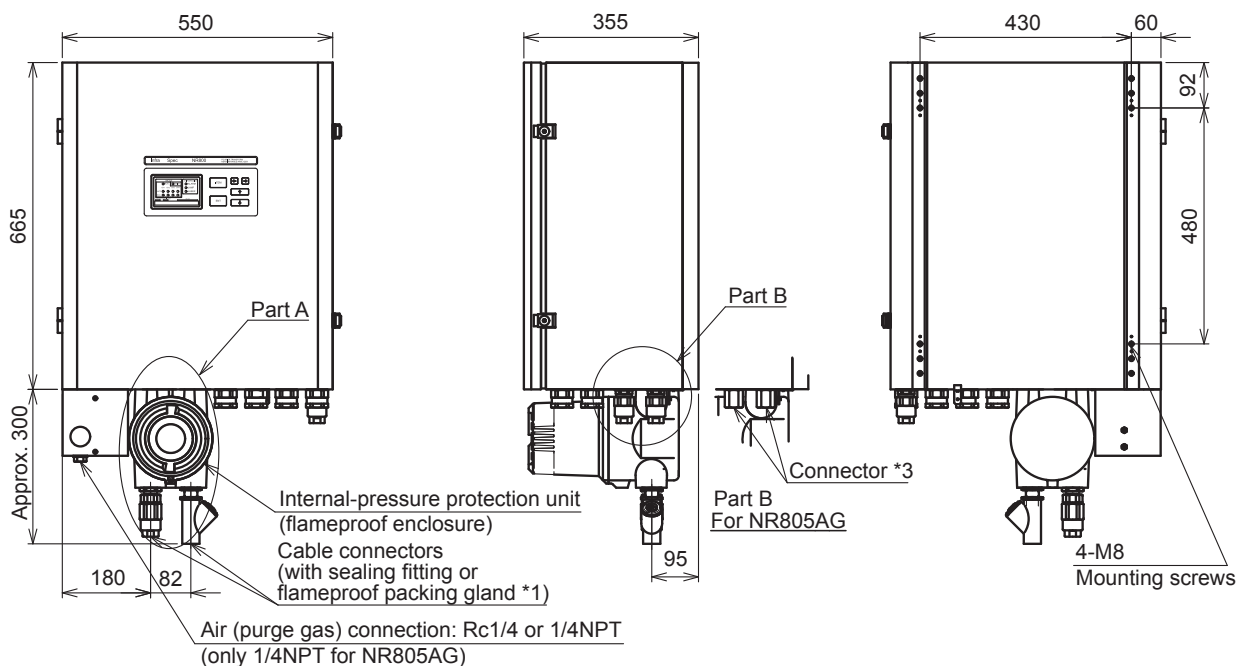

Connection:
3/4NPT
Part A
For NR805AG

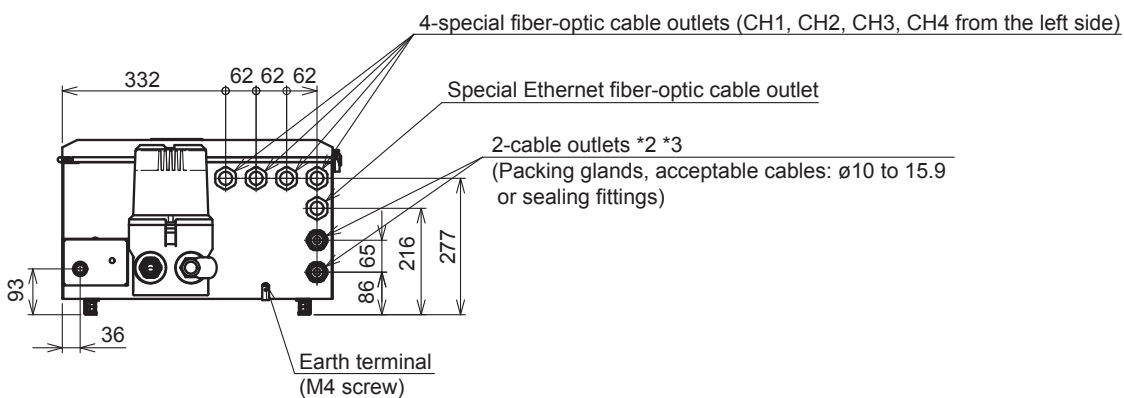

*1: The cable OD for flameproof packing gland is $\phi 8$ to $\phi 15.9$ mm.

*2: In the case of NR805AG, Since attached ferrite core are used, the practical cable OD is up to $\phi 13$ mm.

*3: The connector of NR805AG is 3/4NPT.

Note: The wall shall be designed to withstand four times the weight of the NR800.

- With wall-mounting brackets (Suffix code: B)

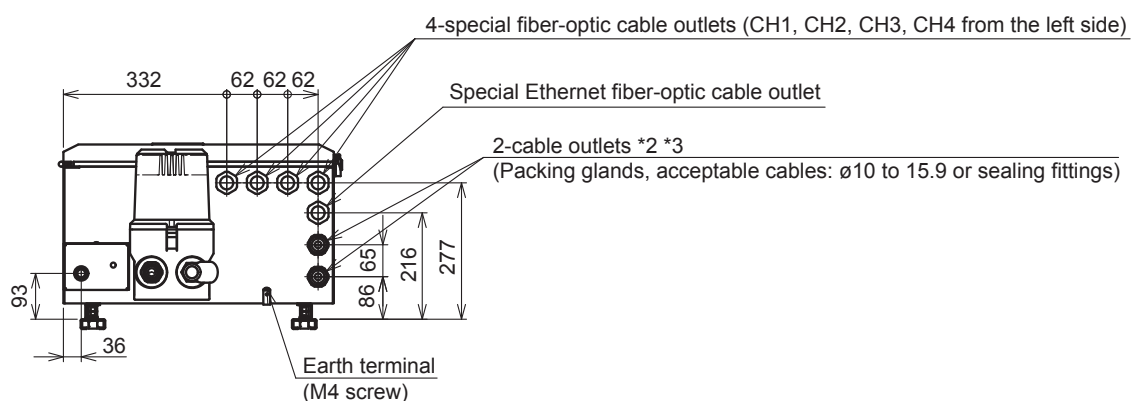
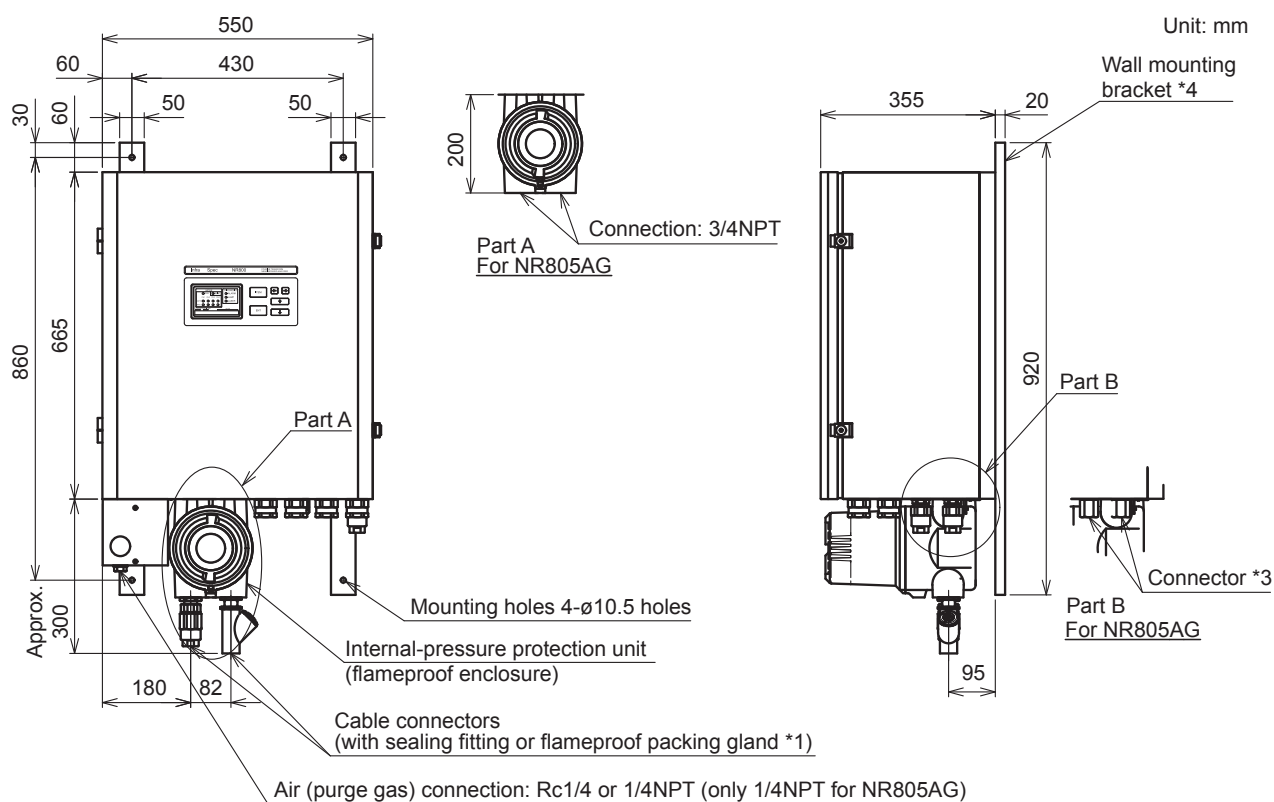

- *1: The cable OD for flameproof packing gland is ϕ 8 to ϕ 15.9 mm.
 *2: In the case of NR805AG, Since attached ferrite core are used, the practical cable OD is up to ϕ 13 mm.
 *3: The connector of NR805AG is 3/4NPT.
 *4: The wall shall be designed to withstand four times the weight of the NR800.

- With free standing rack (Suffix code: C)

Unit: mm

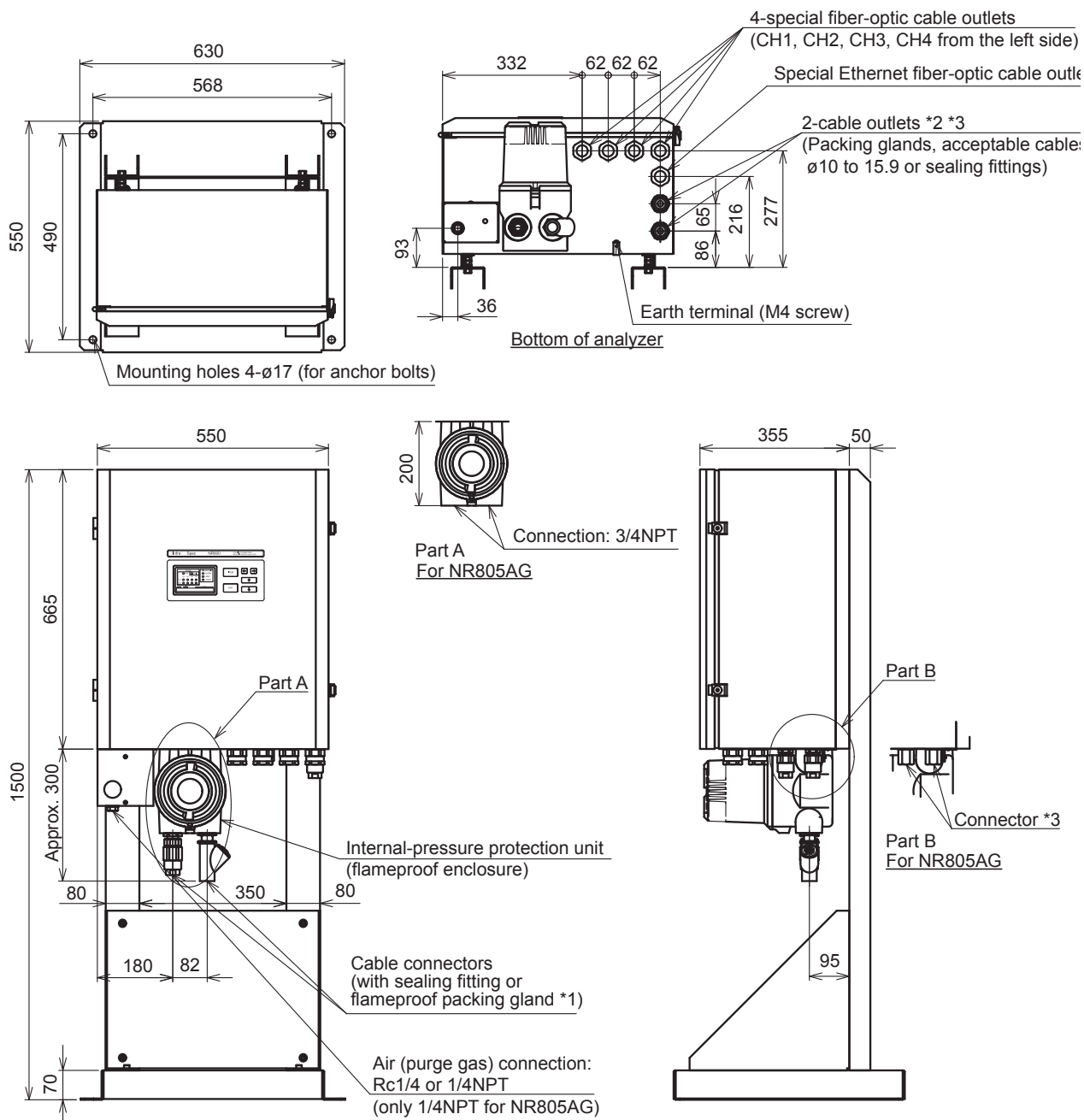

- *1: The cable OD for flameproof packing gland is $\varnothing 8$ to $\varnothing 15.9$ mm.
- *2: In the case of NR805AG, Since attached ferrite core are used, the practical cable OD is up to $\varnothing 13$ mm.
- *3: The connector of NR805AG is 3/4NPT.

2.2 I/O Unit

2.2.1 Overview

The I/O unit is an input/output interface between the analyzer and external monitor/control systems such as DCS. The I/O unit connects with NR800 analyzer via serial communications (RS-422). Up to two I/O units can be connected to the analyzer, and one of which can incorporate the contact input for stream switching and analogue input.

2.2.2 Specifications

Power supply: See section "3. Utility Specifications".

Insulation resistance: 5 M Ω or more, 500 V DC

Withstand voltage: 1500 V AC for 1 min.

Analogue output:

Output data: Measurement results (Properties and concentration)

Number of outputs: 0 to 40

Output specifications:

Item	Description
Output range	4 to 20 mA DC (3.0 to 21.0 mA DC, Floating-common type)
Isolation method	Between output terminals and internal circuit: Photo coupler isolation Between output terminals: non-isolated, Common negative
Withstand voltage	500 V DC for 1 min.
Allowable load resistance	600 Ω or less
12-bit D/A converter resolution	5.7 μ A
System accuracy	\pm 0.5 % of full scale

Separately, 24V DC power supply is required (see section "2.2.3 Model and Suffix codes" and "3. Specifications"). Connect a short-cable (*) to unused analog output terminal between [OUT+] and [OUT-]. If not, the ALM indicator blinks of an analog output module.

(*) Cable specifications:

Size: More than 0.2 mm² (AWG24)

Voltage rating: More than 300 V

Temperature rating: More than 60°C

Flame rating: Equivalent to VW-1

Screw size of terminal on the side of the analog output module: M3.5

Contact output:

Alarm	Quantity of outputs	Alarm	Quantity of outputs
General	1	Outlier	4
Communication failure	1	I/O unit failure	1
Operating mode	5	-	-

Contact output specifications:

Item		Description	
I/O unit failure	Rating	24 V DC, 0.3 A	
	Action and number	1 normally open and 1 normally closed (shared common)	
Alarm, operating mode, and outlier detection	Insulation method	Mechanical isolation	
	Rated load voltage	DC	24 V
		AC	100 to 240 V
	Maximum load current	2 Amps/point, 8 Amps/common	
	Servicing life	Mechanical	At least 20 million actions
		Electrical	At least 100 thousand actions
	Surge killer	None	
Number per common	8 points/common		
External power supply	Not required.		

Contact input:

Description:

Stream identification for multi-stream sampling unit:
8 points, status signals to identify sample streams that pass through measurement cells.

Measurement enabled (stream valid):

4 points, status signals to confirm that samples inside the measurement cells are ready for measurement.

Input unit specifications:

Item	Description
Input type	Voltage free contact
Common terminal	Common to 8 points
Isolation method	Transformer isolation
Withstand voltage	Between external connectors collectively and internal circuit: 500 V DC for 1 min.
Off-state open-circuit voltage	5 to 7 V
On-state load current	1 to 3 mA
On-state load resistance	200 Ω or smaller
Off-state load resistance	100 Ω or larger

Provide external contact-input signals meeting the above requirements.

Analogue input:

Input data and number: Analogue output compensation signal, 4 points

Input specifications:

Item	Description
Input range (actual)	1 to 5 V DC (-0.25 to 5.25 V DC)
Isolation method	Between input terminals and internal circuit: photo coupler isolation Between input terminals: non-isolated, negative common
Withstand voltage	500 V DC for 1 min.
Input resistance	1 M Ω
12-bit A/D converter resolution	1 to 5 V DC: 1.4 mV
System accuracy	\pm 0.5 % of full scale at 0 to 40°C

Installation requirements: See section "4.

Installation Location Requirements".

Mounting: Wall mounting

External connection terminal: M3.5 screw

Drip-proof and dust-proof construction:

IP4X (with enclosure)

2.2.3 Model and Suffix codes

(1) NR893AG: for NR801AG and NR805AG analyzer

[Style: S2]

Model	Suffix Code	Option Code	Description
NR893AG	IO unit (non explosion-proof)
Language	-E	English
Analyzer	1 2	NR805AG (Explosion-proof model) (*1) NR801AG (General Purpose model)
Contact input for stream switching	A B	Available None
Analogue input for compensation	A B	Available None
Number of analogue outputs	-00 -04 -08 -12 -16 -20 -24 -28 -32 -36 -40	None 4 8 12 16 20 24 28 32 36 40
Enclosure	-A -B -C	Number of analog outputs: 0 to 12 Number of analog outputs: 0 to 28 Number of analog outputs: 0 to 40
-	-N	Always "-N"

*1: Always specify 1 for use with an explosion-proof model. This blocks the communication signal upon receiving a power-off signal from the Analyzer, thus ensuring the explosion-proof integrity of the analyzer.

(2) NR893JG: for NR801JG and NR805JG analyzer

[Style: S2]

Model	Suffix Code	Option Code	Description
NR893JG	IO unit (non explosion-proof)
Language	-E -J	English Japanese
Analyzer	1 2	NR805JG (Explosion-proof model) (*1) NR801JG (General Purpose model)
Contact input for stream switching	A B	Available None
Analogue input for compensation	A B	Available None
Number of analogue outputs (*2)	-00 -04 -08 -12 -16 -20 -24 -28 -32 -36 -40	None 4 8 12 16 20 24 28 32 36 40
-	-N	Always "-N"
-	-N	Always "-N"
Option		/C	With enclosure included 24VDC power supply unit for analog output. (*2)

*1: Always specify 1 for use with an explosion-proof model. This blocks the communication signal upon receiving a power-off signal from the Analyzer, thus ensuring the explosion-proof integrity of the analyzer.

*2: Separate 24 V DC power supply required when using an analogue output and option code "/C" are not specified. (see "3. Utility Specifications").

2.2.4 External dimensions and weight:

(1) NR893AG

Paint color: Light beige (Munsell 5Y 7/ 1 or equivalent)

Unit: mm

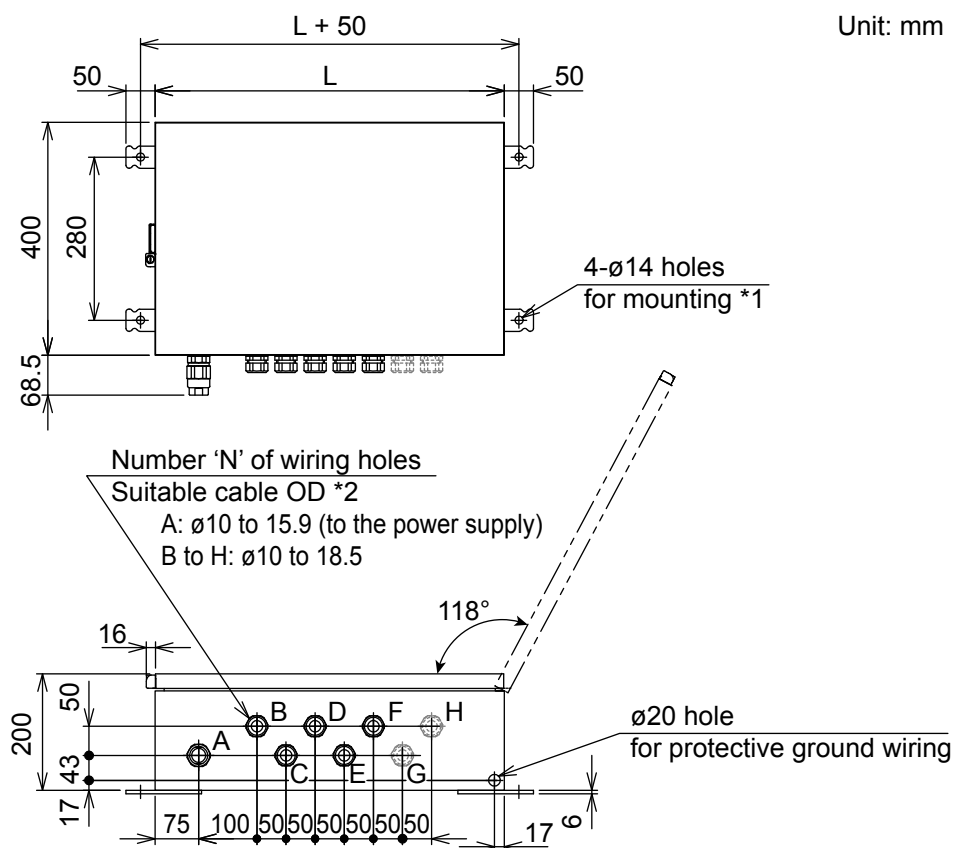

Enclosure code	Number of analog outputs	L (mm)	N	Approximate Weight
-A	0 to 12	400	6 (A to F)	15.5 kg
-B	0 to 28	500	7 (A to G)	17.5 kg
-C	0 to 40	600	8 (A to H)	20.0 kg

*1: The wall shall be designed to withstand four times the equipment's weight.

*2: Since attached ferrite cores are used, the practical cable OD are up to ø13 mm.

(2) I/O unit Without enclosure (only model NR893JG)

- For Explosion proof analyzer unit
- The size of IO unit for general purpose analyzer unit is the same as above figure but RS-422/232C converter power supply case removed.

Paint color: Baseplate, RS-422/232C converter power supply case;

Module colors: Light cobalt blue (Munsell 6.2PB4.6/ 8.8 or equivalent), lamp black (Munsell 0.8Y2.5/0.4 or equivalent)

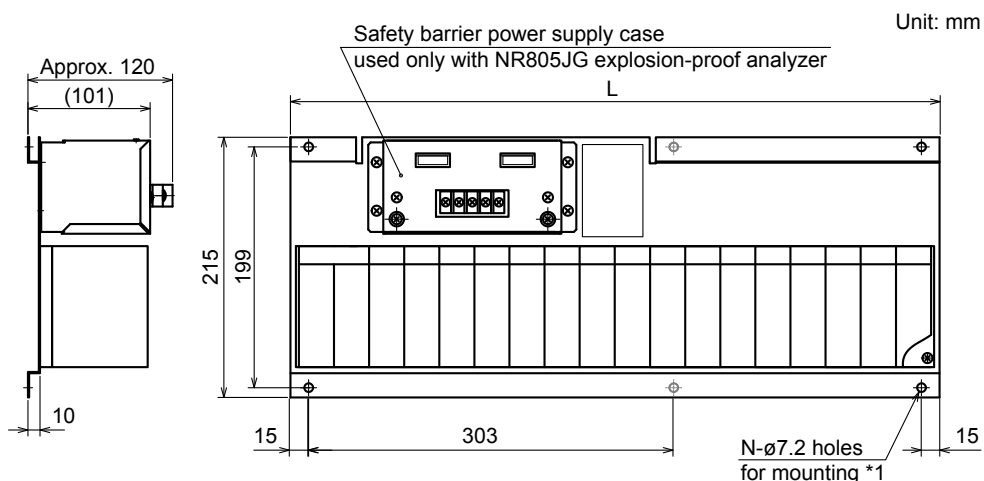

Number of analog outputs code	Number of analog output points	L (mm)	N	Approximate Weight
-00, -04, -08, -12	None, 4, 8, 12	333	4	6.5 kg
-16, -20, -24, -28	16, 20, 24, 28	450	6	7.0 kg
-32, -36, -40	32, 36, 40	537	6	7.5 kg

*1: The wall construction should be withstood a force of four times the weight.

(3) With enclosure (Option code: /C)

Paint color: Light beige (Munsell 5Y 7/ 1 or equivalent)

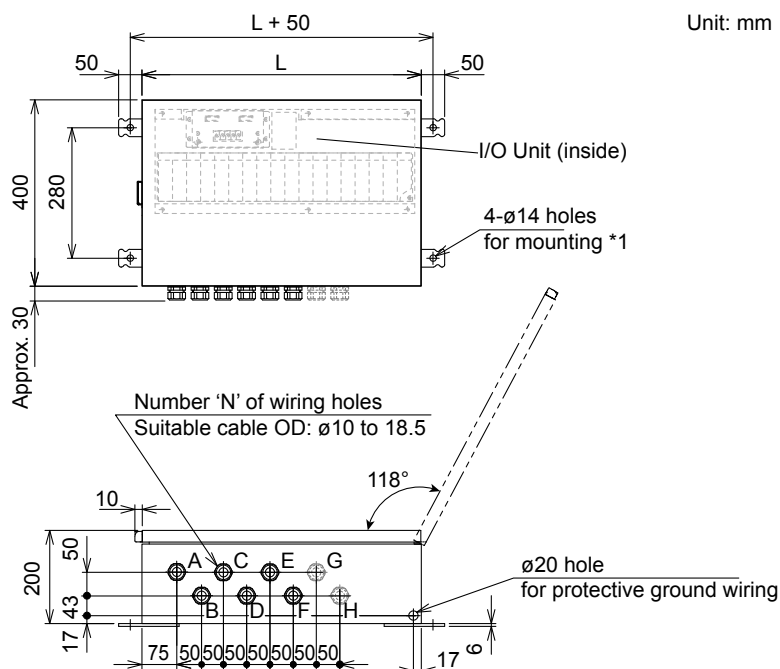

Number of analog outputs code	Number of analog output points	L (mm)	N	Approximate Weight
-00, -04, -08, -12	None, 4, 8, 12	400	6 (A to F)	15.5 kg
-16, -20, -24, -28	16, 20, 24, 28	500	7 (A to G)	17.5 kg
-32, -36, -40	32, 36, 40	600	8 (A to H)	20.0 kg

*1: The wall shall be designed to withstand four times the weight of the NR800

2.3 Measurement Cells

2.3.1 Flow through Cell

(1) Specifications

Optical path length:	1, 2, 5, 10, or 20 mm
Fiber-optic connector:	FC type
Wetted part material:	Fluoro rubber, Kalrez 4079, 316SS, PTFE, Borosilicate crown glass, or Sapphire
Sample pressure range:	Atmospheric pressure up to 1.9 MPa G
Sample temperature range:	-5°C to +80°C (It varies by the materials of O-ring. Contact Yokogawa for further information.)
Sample connection:	Female Rc1/4
Installation angle:	Vertical
Installation location requirements:	See section "4. Installation Condition".
Weight:	Approx. 3 kg

(2) Model and Suffix Codes

[Style: S1]

Model	Suffix Code	Option Code	Description
NR510	Flow through cell
Window material and optical path length	-B00	Borosilicate crown glass, 10 mm, with variable optical path adapter (1, 2, 5, or 20 mm)
	-B01	Borosilicate crown glass, 1 mm
	-B02	Borosilicate crown glass, 2 mm
	-B05	Borosilicate crown glass, 5 mm
	-B10	Borosilicate crown glass, 10 mm
	-B20	Borosilicate crown glass, 20 mm
	-S00	Sapphire, 10 mm, with variable optical path adapter (1, 2, 5, or 20 mm)
	-S01	Sapphire, 1 mm
	-S02	Sapphire, 2 mm
	-S05	Sapphire, 5 mm
	-S10	Sapphire, 10 mm
-S20	Sapphire, 20 mm	
Body material	SUS	Stainless steel, 316SS
O-ring material	-B	Fluoro rubber
	-K	Kalrez 4079
-	-N	Always "-N"
-	-N	Always "-N"

(3) External Dimensions

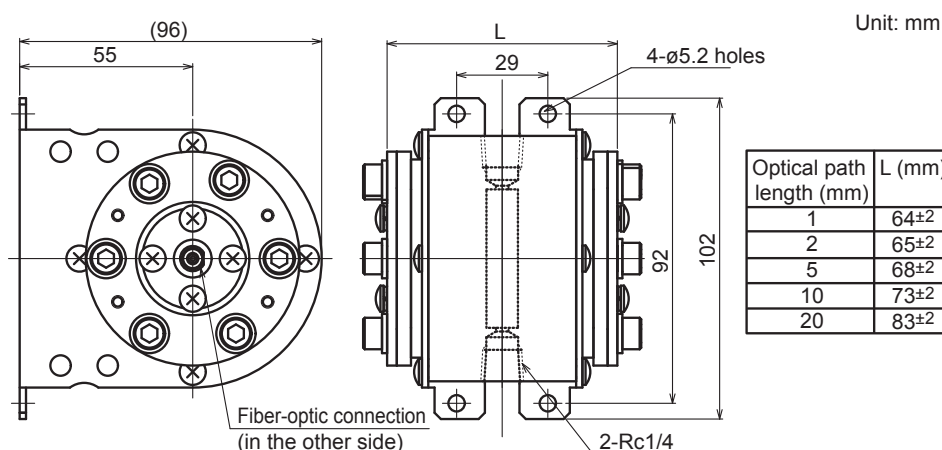

2.3.2 Flow through Cell with Constant Temperature Water Tube

(1) Specifications

- Optical path length: 1, 2, 5, 10, or 20 mm
- Fiber-optic connector: FC type
- Wetted part material: Fluoro rubber, Kalrez 4079, 316SS, PTFE, Borosilicate crown glass, or Sapphire
- Sample pressure range: Atmospheric pressure up to 1.9 MPa
- Sample temperature range: +5°C to +80°C (It varies by the materials of O-ring. Contact Yokogawa for further information.)
- Constant water temperature range: +5°C to +80°C (It varies by the materials of O-ring. Contact Yokogawa for further information.)
- Sample connection: Female Rc1/4
- Connection for water with constant temperature: 6-mm outside diameter, copper tube
- Installation angle: Vertical
- Installation location requirements: See section "4. Installation Condition".
- Weight: Approx. 3 kg

(2) Model and Suffix Codes

[Style: S1]

Model	Suffix Code	Option Code	Description
NR512	Flow through cell with constant temperature water tube
Window material and optical path length	-B00	Borosilicate crown glass, 10 mm, with variable optical path adapter (1, 2, 5, or 20 mm)
	-B01	Borosilicate crown glass, 1 mm
	-B02	Borosilicate crown glass, 2 mm
	-B05	Borosilicate crown glass, 5 mm
	-B10	Borosilicate crown glass, 10 mm
	-B20	Borosilicate crown glass, 20 mm
	-S00	Sapphire, 10 mm, with variable optical path adapter (1, 2, 5, or 20 mm)
	-S01	Sapphire, 1 mm
	-S02	Sapphire, 2 mm
	-S05	Sapphire, 5 mm
	-S10	Sapphire, 10 mm
-S20	Sapphire, 20 mm	
Body material	SUS	Stainless steel, 316SS
O-ring material	-B	Fluoro rubber
	-K	Kalrez 4079
-	-N	Always "-N"
-	-N	Always "-N"

(3) External Dimensions

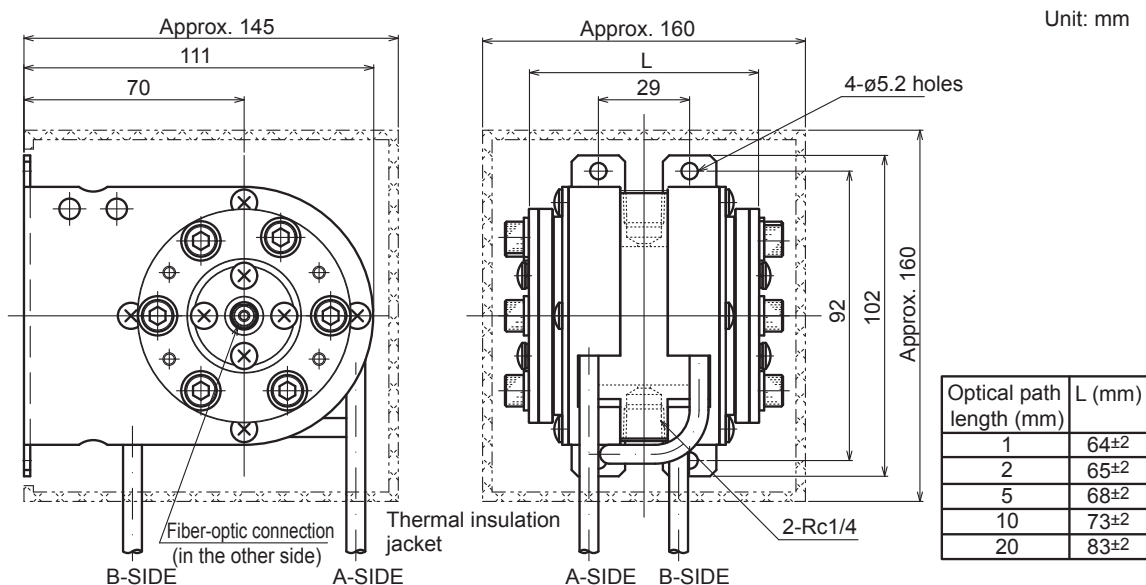

2.3.3 Special measurement cell

This clause describes PFA flow-through type special cell.

(1) Specifications

Optical path length:	1, 2, 5, or 10 mm
Fiber-optic connector:	FC type
Wetted part material:	PFA, Kalrez 4079, Morisei perfloro (MP4275B), or Sapphire (Stainless steel is partly used as non-wetted parts.)
Sample pressure range:	Atmospheric pressure up to 0.3 MPa G
Sample temperature range:	5°C to 80°C
Sample connection:	1/4 inches (Ø6.35 x Ø3.95 mm) PFA tube, or Ø6 x Ø4 mm PFA tube (length: 3000 mm)
Installation angle:	Vertical
Installation location requirements:	See section "4. Installation Condition".
Weight:	Approx. 1.5 kg

(2) Model and Suffix Codes

[Style: S1]

Model	Suffix Code	Option Code	Description
NR511	Special measurement cell
Window material and optical path length	-S01	Sapphire, 1 mm
	-S02	Sapphire, 2 mm
	-S05	Sapphire, 5 mm
	-S10	Sapphire, 10 mm
Body material	P	PFA
O-ring material	-K	Kalrez 4079
	-P	Morisei perfloro (MP4275B)
Tube	-A	1/4 inches (Ø6.35 x Ø3.95 mm), 3000 mm, PFA
	-B	Ø6 x Ø4 mm, 3000 mm, PFA
Option		/Z	Always add "/Z"

(3) External Dimensions

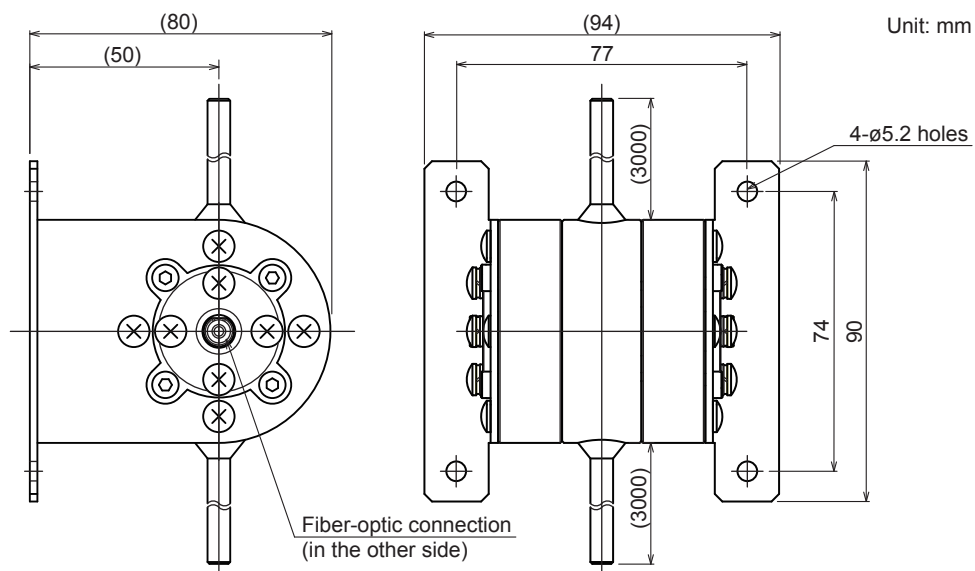

2.3.4 In-situ probe

(1) Specifications

Fiber-optic connector:	FC type
Wet part material:	
Body;	Hastelloy C-276 or UNS S31603 (Stainless steel 316L)
Others;	Sapphire, Hastelloy C-276, Gold
Sample pressure range:	Atmospheric pressure to 0.98 MPa *
Sample temperature range:	Normal temperature to 80°C *
Purge gas connection:	Female 1/8 NPT x 2
Fiber-optic entrance:	Female 1 NPT
Installation angle:	Vertical (Insert portion is downward) or Horizontal
Installation location requirements:	See section "4. Installation Condition".
Weight:	Approx. 5 kg (excluding flange)

*: The specifications above apply to the case when the flange is JIS10K. If you use sample pressure or sample temperature outside the range shown above, please contact our sales representatives regarding the specific conditions of your demand. We will provide some adequate proposals which fit your particular needs. (Installation example 10 MPa, 300°C)

(2) Model and Suffix Codes

FIR200/Z

(3) External Dimensions

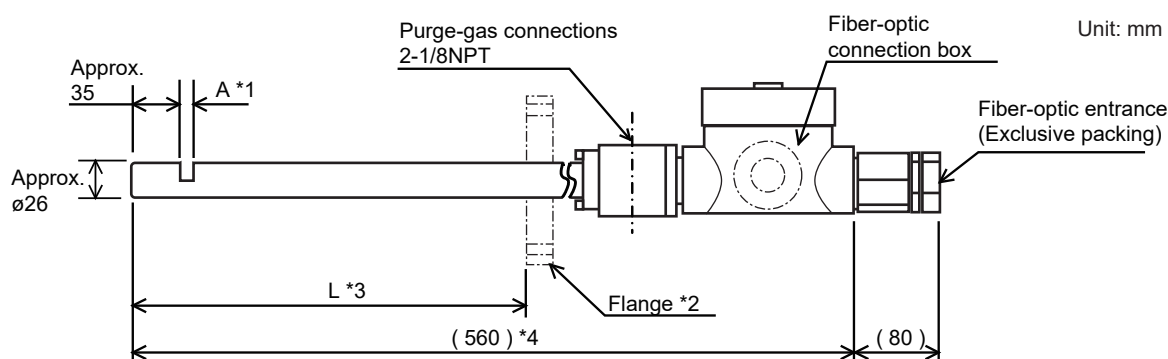

*1: Optical path length "A": 2/5/10 mm, selectable (Dependent on sample conditions, measurement items, measurement range, etc. Consult Yokogawa.)

*2: Mounting flange (Hastelloy C-276/UNS S31603 comparable) should be provided by customer.

*3: Specify length "L" within the range 150 to 250 mm.

*4: The shape and size of connection box may change.

Note 1: Keep the temperature at the connection of the fiber-optic cable at 80°C or below. If the temperature at the connection exceeds 80°C, the connection box should be purged with clean, dry air, or other appropriate measures should be taken. In this case, the connection box may be different in shape and size from the one shown above. If a fiber-optic cable for measurement is exposed to radiant heat, it should be shielded.

Note 2: Dimensions of each part may change without prior notice.

2.4 Fiber-optic Cables for measurement

Fiber-optic cables connect an analyzer to measurement cell. Select appropriate cables to meet your application requirement, e.g., wavelengths scanning range.

2.4.1 Silica Fiber-optic Cable

(1) Specifications

Applicable wavelength range:	900 to 2100 nm
Connector:	Double-end FC or FC-SMA type
Structure:	Dual (for sample and reference) or single (sample), two-core, protected by resin-coated stainless flexible tube
Minimum bending radius:	100 mm. To reduce optical attenuation, make the radiuses along the cable as large as possible when laying cables.
Installation location requirements:	See section "4. Installation Condition".
Cabling:	Conduit protected cabling is recommended.

(2) Model and Suffix Codes

a. Single fiber-optic cable

[Style: S1]

Model	Suffix Code	Option Code	Description
NR821	Single fiber-optic cable for wavelength of 900 to 2100 nm
Connector	-FF -FS	Double-end FC type FC type on analyzer side and SMA type on measurement cell side
Cable length	-L005 -L010 -L015 -L020 -L025 -L030 -L035 -L040 -L045 -L050 -L060 -L070 -L080 -L090 -L100 -L150 -L200 -L300	5 m 10 m 15 m 20 m 25 m 30 m 35 m 40 m 45 m 50 m 60 m 70 m 80 m 90 m 100 m 150 m 200 m 300 m
-	-000	Always "-000"

b. Dual fiber-optic cable

[Style: S1]

Model	Suffix Code	Option Code	Description
NR822	Dual fiber-optic cable for wavelength of 900 to 2100 nm
Connector	-FF -FS	Double-end FC type FC type on analyzer side and SMA type on measurement cell side
Cable length	-L005 -L010 -L015 -L020 -L025 -L030 -L035 -L040 -L045 -L050 -L060 -L070 -L080 -L090 -L100 -L150 -L200 -L300	5 m 10 m 15 m 20 m 25 m 30 m 35 m 40 m 45 m 50 m 60 m 70 m 80 m 90 m 100 m 150 m 200 m 300 m
-	-000	Always "-000"

(3) External Dimensions

A dual fiber-optic cable is a set of two single fiber-optic cable of the same specification.

• Double-end FC connector

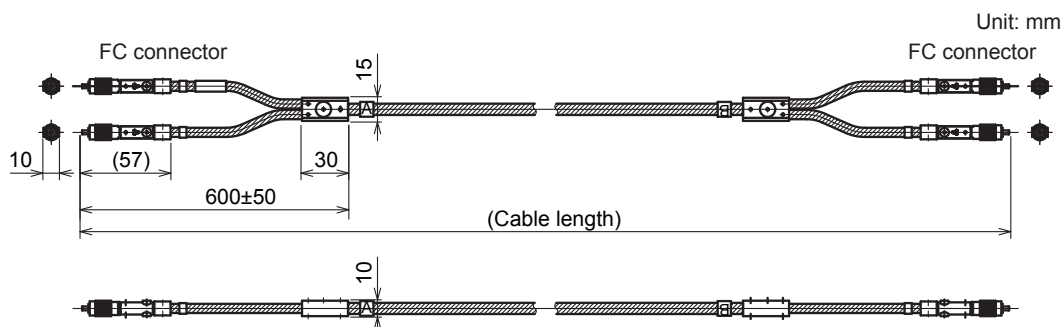

• FC (analyzer) - SMA (measurement cell) connector

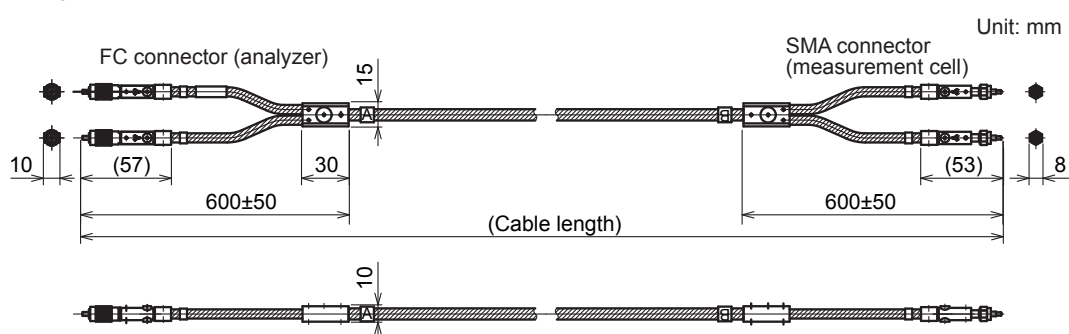

2.4.2 Fluoride Fiber-optic Cable

(1) Specifications

Applicable wavelength range:	900 to 2500 nm
Connector:	Double-end FC type or FC-SMA type
Structure:	Dual (for sample and reference) or single (sample), two-core, protected by resin-coated stainless flexible tube
Minimum bending radius:	Analyzer side; 100 mm, Measurement side; 120 mm To reduce optical attenuation, make the radiuses along the cable as large as possible when laying cables.

Installation location requirements: See section "4. Installation Condition".

Note: Fluoride, a material used in the NR823 and NR824 fiber-optic cables, has the deliquescence properties. When storing these cables, take appropriate measures to prevent moisture, e.g., a cable should be placed with desiccant in a sealed moisture-barrier plastic bag. Replace the desiccant regularly.

(2) Model and Suffix Codes (Model code to include fibers for Analyzer–Cell(probe)–Analyzer)

a. Single fiber-optic cable

Model	Suffix Code	Option Code	Description
NR823	Single fiber-optic cable for wavelength of 900 to 2500 nm
Connector	-FF	Double-end FC type
	-FS	FC type on analyzer side and SMA type on measurement cell side
Cable length	-L003	3 m
	-L004	4 m
	-L005	5 m
-	-000	Always "-000"

[Style: S1]

b. Dual fiber-optic cable

Model	Suffix Code	Option Code	Description
NR824	Dual fiber-optic cable for wavelength of 900 to 2500 nm
Connector	-FF -FS	Double-end FC type FC type on analyzer side and SMA type on measurement cell side
Cable length	-L003 -L004 -L005	3 m 4 m 5 m
-	-000	Always "-000"

(3) External Dimensions

A dual fiber-optic cable is a set of two single fiber-optic cable of the same specification. (Connect the longer end to the measurement cell side.)

• Double-end FC connector

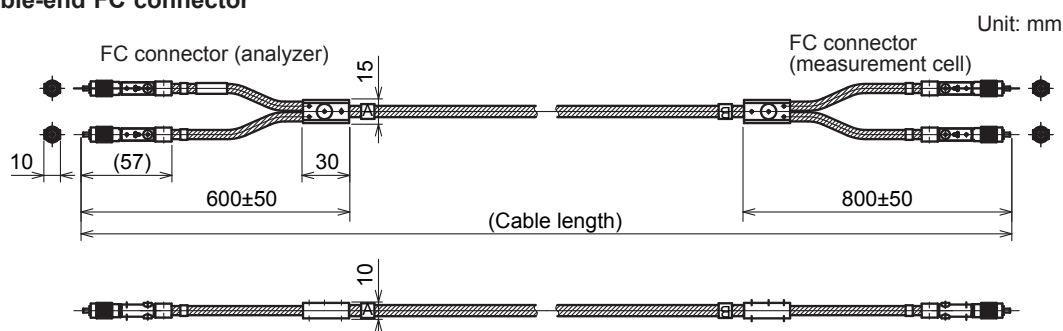

• FC (analyzer) - SMA (measurement cell) connector

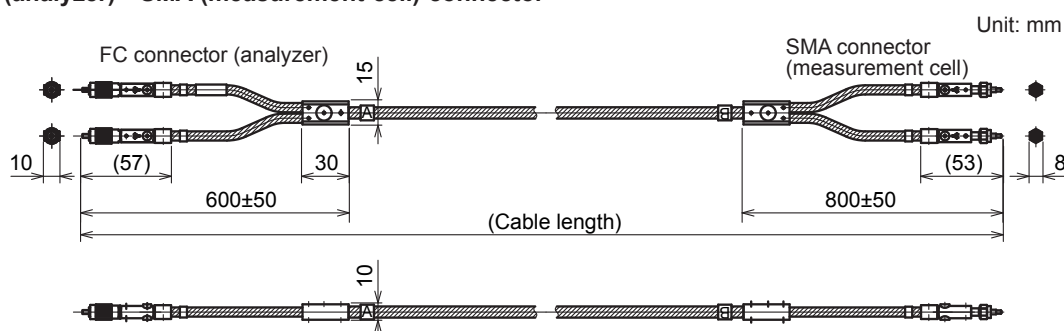

2.5 RS-422-to-RS-232C Converter (Part Number: K9404LA or K9404LD)

This unit receives data from the analyzer via RS-422 and converts them to RS-232C serial interface, therefore it helps the data transmission between the analyzer and I/O unit or monitor/control system. This unit also blocks communication signals when it receives a power-off signal from the analyzer, thus ensuring the explosion-proof integrity.

2.5.1 Specifications

Power supply:	See section "3.1 Power Supplies". M4 screw terminal connection.
Signal terminals:	Analyzer main unit side (RS-422): M3.5, output side (RS-232C): Female Dsub 25-pin
Grounding type:	100 Ω or lower
Installation location requirements:	See section "4. Installation Condition".
Housing structure:	Desktop (K9404LA), Screw cramp (K9404LD)
Weight:	Approx. 2 kg
Note:	The converter does not carry the CE Marking. An appropriate housing should be provided by customer, if necessary.

2.5.2 Terminal Diagram

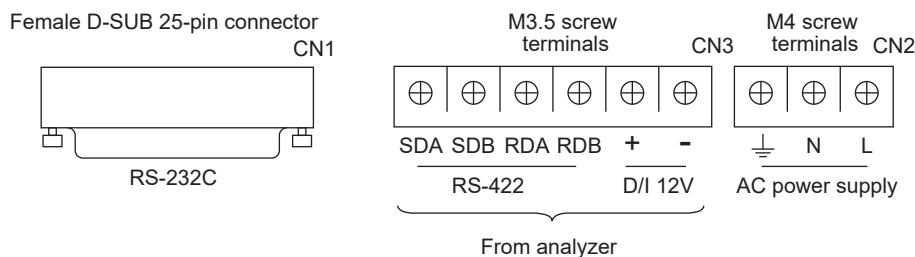

2.5.3 RS-232C Communication Straight Cable

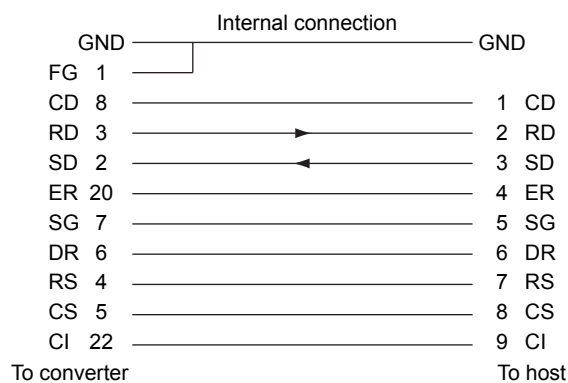

2.5.4 External Dimensions

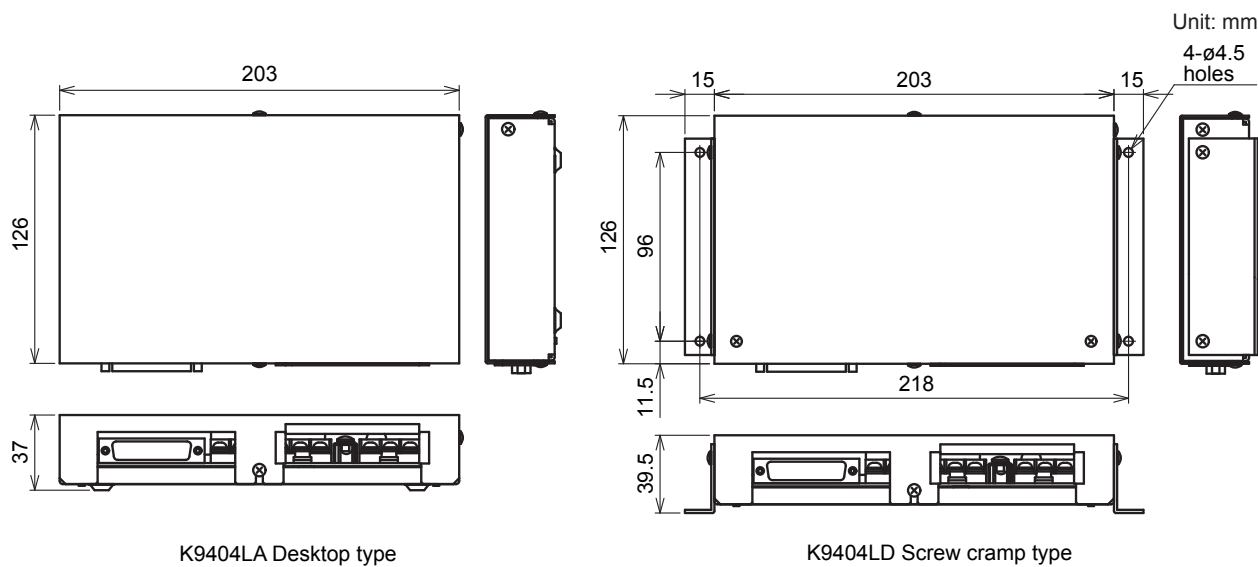

2.6 Ethernet Fiber-optic Cable

Cable for Ethernet communication between the analyzer and the engineering PC.

2.6.1 Specifications

Length:	Up to 20 m
Connector:	ST type
Structure:	Two-core, protected by stainless flexible tube
Installation location requirements:	See section "4. Installation Location Requirements".
Minimum bending radius:	50 mm. To reduce optical attenuation, make the radiuses along the cable as large as possible when laying cables.

2.6.2 Model and Suffix Codes

[Style: S1]

Model	Suffix Code	Option Code	Description
NR895	Ethernet fiber-optic cable
Length *1	-L003	3 m
	-L005	5 m
	-L010	10 m
	-L020	20 m
-	-000	Always "-000"
Option		/JB	With junction box *2

- *1: For a total cable distance of 20 m or longer, an additional fiber-optic cable (fitted with ST connectors) must be provided by the user.
See section "6.2 Ethernet Communication" for the cable specification of user provisions.
- *2: The Junction box is for connection between an NR895 fiber-optic cable and the additional fiber ones provided by the user.

2.6.3 External Dimensions

(1) Fiber-optic Cable

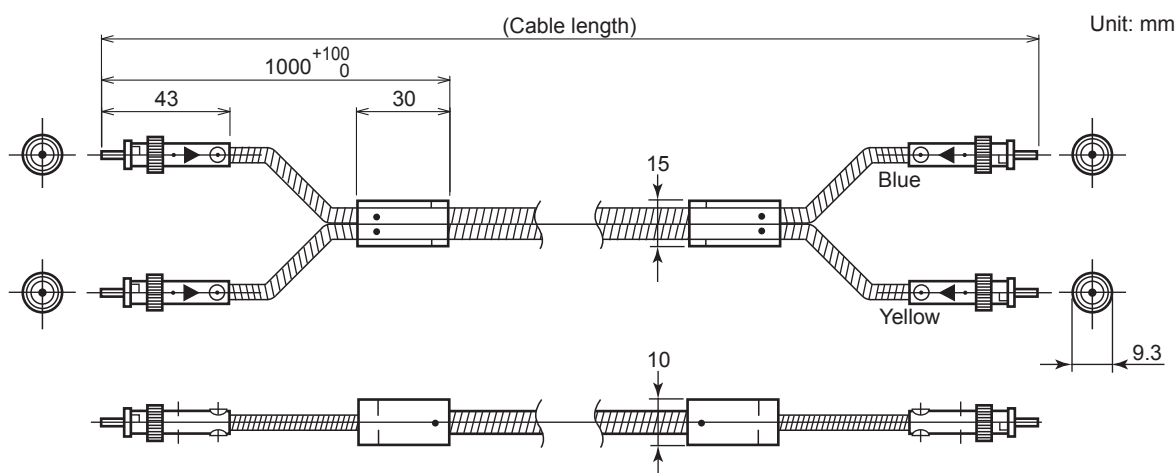

(2) Junction Box for Ethernet fiber-optic cables (Option code: /JB)

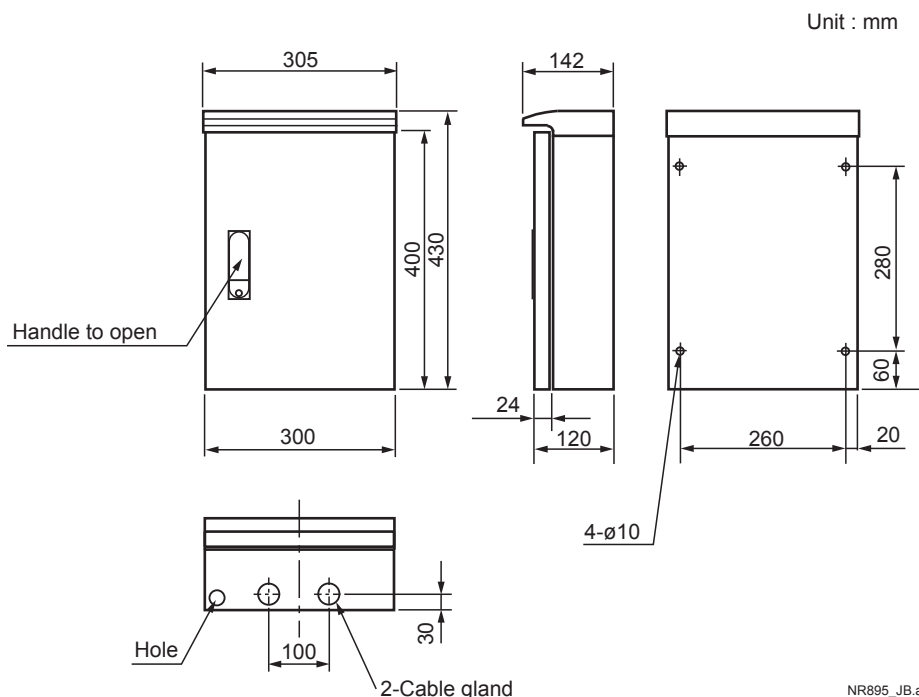

Housing structure: IP44
 Coating: Epoxy resin coating
 Paint color: Light beige (equivalent to Munsell 5Y7/1)
 Material: Iron

NR895_JB.z

Weight: Approx. 10 kg

2.7 SPECTRLAND2 Measurement and Maintenance Software

2.7.1 Overview

SPECTRLAND2 is an application software that controls NR800 operation and monitoring on a PC. It displays the analyzer status, instructs measurement and sets parameters for the analyzer. To use SPECTRLAND2, first install it in the engineering PC.

The continuous operation of SPECTRLAND2 for extended periods of time is not guaranteed.

Main Features

- Instructs the analyzer to measure spectra, stores data and displays. The measured spectra can be used for calibration modeling.
- Shows trend graphs of the measurements and saves them to files during a continuous measurement.
- Sets parameters for continuous measurement.
- Displays various data of the analyzer, such as operating modes, alarm status, and maintenance data.
- Instructs the analyzer to perform operation mode change, spectra measurement, property value setting, calibration models, and setting measurement conditions.

2.7.2 Main Windows

(1) Manual Spectrum Window

Enables the analyzer to measure spectra, which are to be processed by Chemometrics (Calibration Modeling software). Also allows data to be saved to files and displayed.

(2) Auto Spectrum Window

Allows the user to upload spectra data to the Engineering PC during continuous measurement upon receiving a signal at periodic intervals, outlier detection, or a property value variation failure. This data is displayed for each measuring channel.

(3) Power Spectrum Window

It displays power spectra. This window is available for UB level (equipment supervisor) users.

(4) Interferogram Window

It displays interferogram data collected. This window is available for UB level users.

(5) Real-time Trend Windows

Display measurement values of Nos. 1 to 6 and Nos. 7 to 12 components in two separate trend graph windows for each stream. Up to 10 windows can be open at the same time.

(6) Historical Trend Windows

Display historical trend data saved. Trend data of 24 hours for each stream is saved to a file. Up to 4 windows can be open at the same time.

(7) Parameter Window

Displays the current parameter settings for the analyzer. In addition, UB level users can change the settings.

(8) Alarm Status/History Windows

The Alarm Status window displays the active alarms for the analyzer, while the Alarm History window displays all the past alarms. The alarm history can be deleted with commands.

(9) Tab-controlled Maintenance Window

Displays the A/D reference value and servo-related data of the analyzer. This window is available for UC level users.

(10) Tab-controlled Communication Status Window

Displays the communication status between the engineering computer and the analyzer. This window is available for UC level (maintenance) users.

2.7.3 Model and Suffix Codes

Model	Suffix Code	Option Code	Description
NR831	SPECTRLAND2 measurement and maintenance software
Language	-E -J	English Japanese
-	-N	Always "-N"
-	-N	Always "-N"
Option		/UP	Version up

Package contents: One CD-ROM
One user's manual

2.8 Chemometrics Software

2.8.1 Specifications

- Calibration Modeling technique:
Partial least square (PLS) and others

2.8.2 Model and Suffix Codes

Model	Suffix Code	Option Code	Description
NR530	Chemometrics software
Language	-E	English
Type	-V	VEKTOR DIREKTOR
-	-N	Always "-N"

Package contents: One CD-ROM (Install disc/User's manual)
One set of user registration document
One set of license key document

2.9 Sampling Unit

Some applications permit direct link between the process and the measurement cell or you don't need the sampling unit. Please fill out the inquire form (last two pages) to show and contact our representatives. We will select the optimum system to suit the application of your demand.

● Example of Sampling System

The following introduces a conceptual sampling unit for measuring the properties (RON, RVP, Distillation etc.) of gasoline blending in a petroleum refinery. Note that each sampling unit should be designed for each application; designs will vary.

Measurement Sample Conditions

Item	Condition	
Fluid to be measured	Gasoline	
Sample inlet/outlet condition	Inlet pressure	0.3 to 0.9 MPa G
	Outlet pressure	0.3 to 0.9 MPa G
	Inlet temperature	0°C to +40°C

Notes

- 1: When samples do not contain free water content, a coalescer (CF1) is not required.
- 2: When samples do not have bubbles, a degasser (DG1) is not required.
- 3: If the pressure difference between the sample inlet and outlet is greater than 0.3 MPa, a sampling pump (PU1) is not required.

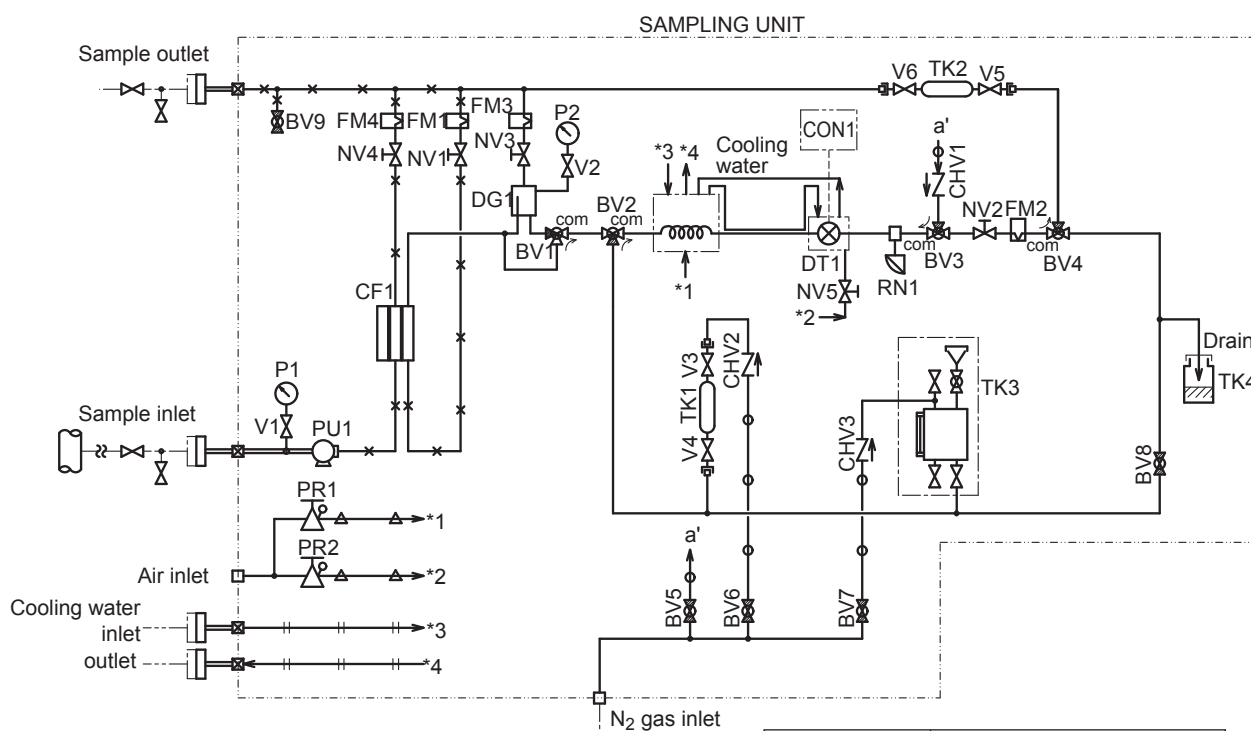

<connection>

- : JIS 10K-15A-RF
- : Rc1/2
- : Rc1/4

<piping>

- : SUS316TP 15A sch40
- : ø12/ø10 SUS316
- : ø8/ø6 SUS316
- : ø4/ø3 Nylon tube
- : ø6/ø4 Nylon tube
- : ø22/ø6 Braid tube

PU1	PUMP
CHV1, 2, 3	CHECK VALVE
BV1, 2, 3, 4	3-WAY BALL VALVE
BV5, 6, 7, 8, 9	2-WAY BALL VALVE
V1, 2, 3, 4, 5, 6	STOP VALVE
NV1, 2, 3, 4, 5	NEEDLE VALVE
FM1, 2, 3, 4	FLOW METER
PR1, 2	PRESSURE REGULATOR
CF1	COALESCKER FILTER
DG1	DEGASSER
P1, 2	PRESSURE GAUGE
DT1	DETECTOR
TK1, 2, 3, 4	TANK
CON1	InfraSpec NR800
RN1	RESISTANCE TEMP. SENSOR

2.10 Auxiliary Parts *

The recommended replacement intervals for auxiliary parts, listed in Section 2.10.1, Model and Suffix Codes, are set for preventive maintenance and do not guarantee the service life of parts. Actual replacement intervals for auxiliary parts vary depending on operating conditions, sample conditions, and other factors. Be sure to perform preventive maintenance based on operational status of instrument.

The auxiliary parts are classified into two types: those that can be replaced by customer and those that must be replaced by a Yokogawa service engineer.

Prior to replacement, refer to the user's manual and follow the instruction therein.

* Auxiliary parts mean limited life components that are excepted to be in their wear-out failure period within 5 years under normal operating or storage conditions.

Model	Suffix Code	Option Code	Description	Recommended Replacement Interval
NR8SP01	Auxiliary parts set for NR800	
	-01	Sealing packing for analyzer door (for NR801AG/NR805AG/NR801JG/NR805JG)	1 year
	-02	Analyzer cooling fan (5 pcs)	3 years
	-03	Spectrometer support insulator (4 pcs)	3 years
	-04	Lamp (adjusted)	5,000 hours
	-05	Laser head	12,000 hours
	-06	Desiccant for spectrometer (9 pcs)	1 year (Shelf life: 1 year after shipment)
	-07	Desiccant for flow-through cell (10 pcs)*1	3 months
	-08	Sealing packing for analyzer door (for NR805JG/K)	1 year
	-10	O-ring for flow-through cell (JIS P38, FKM (fluoro rubber), 2 pcs)	*1, *2
	-11	O-ring for flow-through cell (JIS P21, FKM (fluoro rubber), 2 pcs)	*1, *2
	-12	O-ring for flow-through cell (JIS P16, FKM (fluoro rubber), 2 pcs)	*1, *2
	-13	O-ring for flow-through cell (JIS P38, Kalrez 4079, 2 pcs)	*1, *2
	-14	O-ring for flow-through cell (JIS P21, Kalrez 4079, 2 pcs)	*1, *2
	-15	O-ring for flow-through cell (JIS P16, Kalrez 4079, 2 pcs)	*1, *2
	-16	Window pane of flow-through cell (borosilicate crown glass, 2 pcs)*3	
	-17	Window pane of flow-through cell (sapphire, 2 pcs)*3	

*1: When a measurement cell is disassembled for service/cleaning, it is recommended that O-rings should be replaced.

*2: Replacement intervals vary depending on sample composition, humidity, pressure, etc. Determine replacement intervals based on actual operational status.

*3: If a window is scratched or fogged, replace the whole set of windows (2 pieces/set).

Please contact Yokogawa, when you need the O-ring for Special measurement cell.

3. Utility Specifications

3.1 Power Supplies

(1) NR800 analyzer

Power supply:

100, 115, 200, 230 V AC, single phase,
50/60 Hz (*1)

Voltage fluctuation:

Rating $\pm 10\%$, 50/60 ± 2 Hz

Power consumption:

Approx. 250 VA

(*1): To be specified. See the corresponding model and suffix codes for details.

(2) RS-422/RS-232C converter

Power supply:

100 to 120 V AC or 200 to 240 V AC,
single phase, 50/60 Hz

Voltage fluctuation:

Rating $\pm 10\%$, 50/60 ± 2 Hz (Don't exceed
250 V AC)

Power consumption:

Approx. 15 VA

(3) I/O unit

AC Power supply:

100 to 240 V AC $\pm 10\%$, single phase,
50/60 Hz $\pm 5\%$

Power consumption:

NR893AG, NR893JG with enclosure

(AO points 0 to 12): Approx. 150 VA

(AO points 16 to 28): Approx. 190 VA

(AO points 32 to 40): Approx. 220 VA

NR893JG without enclosure

(AO points 0 to 40): Approx. 100 VA

DC Power supply:

24 V DC $\pm 10\%$

Power consumption:

Approx. 200 mA / AO 4 points

*: Required when in the NR893AG, NR893JG I/O unit, option code "/C" is not specified.

3.2 Others

(1) Clean, dry air for Analyzer purge (explosion-proof model)

Item	Description
Temperature	-10°C to +40°C
Pressure	0.3 to 0.9 MPa
Dew point	-20°C or lower (under pressure) Compressed air should not dew at the installation ambient temperature.
Cleanliness	Must be free from dust, corrosive, and toxic elements. Impurities, such as oil, cause damage to the optical components. Eliminate them with an activated carbon filter.
Volume;	Approx. 75 L/min (stp.)

(2) Clean, dry air for in-situ probe

Item	Description
Temperature	-10°C to +40°C
Pressure	To be supplied at atmospheric pressure. A regulator and a needle valve to be prepared by the customer.
Dew point	-20°C or lower (at pressure) Compressed air should not dew at the installation ambient temperature.
Cleanliness	Must be free from dust, corrosive, and toxic elements. Impurities, such as oil, cause damage to the optical components. Eliminate them with an activated carbon filter.
Volume;	Approx. 0.3 to 0.5 l/min (stp.). Depend on sample temperature and ambient temperature.

(3) Water for flow through cell with water tube;

Depend on measurement specifications. Temperature, response speed, etc.,

(4) Utility for sampling unit (when used)

Depend on sampling system configuration, sample temperature, response speed, etc.

4. Installation Location Requirements

Avoid physical shock as it may cause damage to the equipment.

4.1 NR800 analyzer, measurement cell, and fiber-optic cable

Item	Description
Location	Hazardous area/non-hazardous area. Outdoor/indoor. Avoid direct exposure to wind, rain, sunlight and radiation heat. Altitude 2,000 m max.
Ambient temperature	-10°C to +40°C
Ambient humidity	5% to 95% RH (no condensation)
Vibration	Install the equipment in a place with minimum vibration (vibration acceleration of 2 m/s ² or less)
Atmosphere	Must not contain corrosive or toxic substances. Must be free from dust.

4.2 RS-422/RS-232C converter and I/O unit

Item	Description
Location	Non-hazardous area, indoor. Avoid direct exposure to wind and rain, sunlight, or radiation heat. Altitude 2,000 m max.
Ambient temperature	+5° C to +35 °C
Ambient humidity	5% to 95% RH (no condensation)
Vibration	Install the equipment in a place with minimum vibration (vibration acceleration of 2 m/s ² or less)
Atmosphere	Must not contain corrosive or toxic substances. Must be free from dust.

4.3 Maintenance Space for NR800 Analyzer

Secure space as below for the operation and easy maintenance.

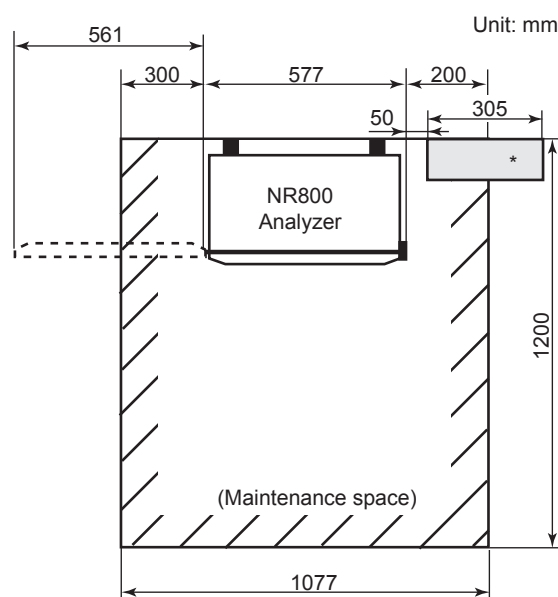

* Junction box for Ethernet fiber-optic cables.
(When NR895/JB is selected.) See section "2.6.3 External Dimensions" for external dimensions.

4.4 Storage Conditions

Avoid physical shock as it may cause damage to the equipment.

Item	Description
Location	Indoor. Avoid direct exposure to wind and rain, sunlight, or radiation heat
Ambient temperature	-10°C to +50°C
Ambient humidity	5% to 95% RH (no condensation)
Vibration	Install the equipment in a place with minimum vibration (vibration acceleration of 2 m/s ² or less)
Atmosphere	Must not contain corrosive or toxic substances. Must be free from dust.

Note: Fluoride, a material used in the NR823 and NR824 fiber-optic cables, has the deliquescence properties. When storing these cables, take appropriate measures to prevent moisture, e.g., a cable should be placed with desiccant in a sealed, moisture-barrier plastic bag and replace the desiccant regularly.

5. Support for Calibration Modeling

5.1 On-site Guidance on Calibration Modeling

Users prepare a sample with its laboratory analysis results. A Yokogawa representative will offer on-site hands on instruction on Calibration Modeling to a personnel from the user's facility while using the sample and the installed analyzer.

5.2 Calibration Modeling

Yokogawa make calibration modeling using the necessary quantity of user-provided samples with laboratory analysis results. A predefined SEP (standard error of prediction) value of 1σ will be used as the measurement target value. The target value, sample quantity, and other details are determined separately for each application upon request.

5.3 Others

Other support options for calibration modeling and maintenance include:

- Sampling test for potential users
- Maintenance contracts
- Sampling/model generation/maintenance consulting service.

Contact a Yokogawa sales representative for further information. We will provide the best solution to fit your needs.

6. Recommended Specifications for Engineering PC and peripherals (provided by user)

6.1 PC

Computer	IBM PC/AT compatible desktop
Operating system (OS)	Microsoft Windows 11 Pro, Microsoft Windows 10 Pro 64 bit
CPU	Intel Core i5 or higher
RAM	8 GB or more
Hard disk space	10 GB (for program) and 25 GB (for data storage) or more
Ethernet adapter	10 Base-T
Display (Resolution)	1024 x 768 pixels or more
Other	CD-R drive is recommended

Note: Tablet mode is not supported.

● Color Printer

Prepare if necessary.

● Connect peripherals and consumables

Prepare if necessary.

6.2 Ethernet Communication

● When fiber-optic cables are used for Ethernet communication (see section "2.6 Ethernet Fiber-optic Cable")

Customer should provide:

- An optical-to-electrical signal converter (850 nm wavelength, for a multimode fiber-optic cable that complies with Ethernet version 2.0 and IEEE 802.3 10Base-T and 10Base-FL standards and is fitted with ST connectors)
- Fiber-optic extension cables
- Electric cables for Ethernet communication

● When electric cables are used for Ethernet communication

Electric cables for Ethernet communication should be provided by customer.

● Additional Ethernet fiber-optic cable

Material and connector: Silica glass fiber with ST connectors

Mode: Multi-mode GI
 Number of cores: 2
 Core/Clad diameters: 50/125 μm
 Applicable wavelength: 850 nm
 Length: 1000 m or less in total including an NR895 fiber-optic cable

● Specifications of electric cable for Ethernet communication

Type: 10Base-T, 8-core shielded, straight connection, RJ-45 connectors
 Note that when an NR895 fiber-optic cable for Ethernet communication is not used, use an Ethernet crossover cable. If you use a hub, consult Yokogawa.

Length: 3 to 40 m
 Finished outside diameter: 5.0 to 7.4 mm

Specification Sheets for inquiry of NR800 series (1/2)

Thank you for your inquiry. Please provide us with the following information on your request. We will quote in response to your inquiry. Fill in the blank and tick/check the appropriate box ()

1. Scope of Quotation

Required: Analyzer Measurement cell/probe, Fiber-optic, Software, User's manual (1 copy)

Optional: Document (Specification for approval ___copy Test certificate ___copy)

- Factory acceptance test
- Calibration Modeling by Yokogawa
- On-site hands-on training of Calibration Modeling

2. General

User's name: _____

Purpose : Control Monitor / alarm Others

Plant name: _____

Document: English Japanese

3. Specifications

Number of measuring channel: 1 ch 2 ch 3 ch 4 ch Possibility of the channel expansion

Analogue output: Need (___ points) Not need

With stream switch input function: Need Not need

Measurement cell / probe: No.1 ch (cell probe) No.2 ch (cell probe)

No.3 ch (cell probe) No.4 ch (cell probe)

Length of fiber-optics: No.1 ch (Laying distance: ___ m) No.2 ch (Laying distance: ___ m)

No.3 ch (Laying distance: ___ m) No.4 ch (Laying distance: ___ m)

Ethernet Fiber-optic Cable: Need (3 m, 5 m, 10 m, 20 m) With junction box

4. Installation Condition

Analyzer: Indoors Outdoors explosion-proof non-ex-proof Toxic / Corrosive ambient

Restricted installation area (___ m x ___ m)

Measurement cell / probe: Indoors Outdoors Toxic / Corrosive ambient

5. Utilities

Power supply: _____ V AC, _____ Hz

Instrument air: (Pressure _____ MPa) None

Note: Clear and dry air is required for purging explosion-proof type analyzer. See section "3.2 Others".

6. Sample condition

Please fill in the next page.

7. Special note

Please make other notes upon device installation if any.

Specification Sheets for inquiry of NR800 series (2/2)

Sample composition / Measuring Constituent List

Please fill out all sample constituent including non-measuring constituent.

No.1 ch Sample name: _____

Sample temperature: _____ to _____ °C, normal _____ °C

Sample pressure: _____ to _____ MPa, normal _____ MPa

Bubble / slurry: Bubble Slurry Others (_____)

	Tick for measuring constituent	Constituent Fill out all constituent	Variation/ measuring range	Normal	Unit
1			to		
2			to		
3			to		
4			to		
5			to		
6			to		
7			to		
8			to		
9			to		
10			to		

No.2 ch Sample name: _____

Sample temperature: _____ to _____ °C, normal _____ °C

Sample pressure: _____ to _____ MPa, normal _____ MPa

Bubble / slurry: Bubble Slurry Others (_____)

	Tick for measuring constituent	Constituent Fill out all constituent	Variation measuring range	Normal	Unit
1			to		
2			to		
3			to		
4			to		
5			to		
6			to		
7			to		
8			to		
9			to		
10			to		

No.3 ch Sample name: _____

Sample temperature: _____ to _____ °C, normal _____ °C

Sample pressure: _____ to _____ MPa, normal _____ MPa

Bubble / slurry: Bubble Slurry Others (_____)

	Tick for measuring constituent	Constituent Fill out all constituent	Variation/ measuring range	Normal	Unit
1			to		
2			to		
3			to		
4			to		
5			to		
6			to		
7			to		
8			to		
9			to		
10			to		

No.4 ch Sample name: _____

Sample temperature: _____ to _____ °C, normal _____ °C

Sample pressure: _____ to _____ MPa, normal _____ MPa

Bubble / slurry: Bubble Slurry Others (_____)

	Tick for measuring constituent	Constituent Fill out all constituent	Variation/ measuring range	Normal	Unit
1			to		
2			to		
3			to		
4			to		
5			to		
6			to		
7			to		
8			to		
9			to		
10			to		