**User's
Manual**

**RC800D
Reagent Type
Residual Chlorine Sensor Unit**

IM 12F04B10-02EN

◆ INTRODUCTION

Thank you for purchasing RC800D Reagent Type Residual Chlorine Sensor Unit, FLXA402T Liquid Analyzer for Turbidity and Chlorine sensor.

This User's Manual contains all essential information for the user to make full use of RC800D and FLXA402T.

Please read the following respective documents before installing and using the instrument.

The related documents are listed as follows.

General Specifications

Contents	Document number	Note
RC800D, FLXA402T Reagent Type Residual Chlorine Analyzer	GS 12F04B10-01EN	Online manual

"EN" in the document number is the language code.

User's Manual

Contents	Document number	Note
RC800D Reagent Type Residual Chlorine Sensor Unit Start-up and Safety Precautions	IM 12F04B10-01EN	Attached to the product (printed manual)
RC800D Reagent Type Residual Chlorine Sensor Unit	IM 12F04B10-02EN	Online manual (This manual)
FLXA402T Liquid Analyzer for Turbidity and Chlorine Start-up and Safety Precautions	IM 12A01G01-01EN	Attached to the product (printed manual)
FLXA402T Liquid Analyzer for Turbidity and Chlorine Installation and Wiring	IM 12A01G01-02EN	Online manual
FLXA402T Liquid Analyzer for Turbidity and Chlorine Operation of Converter	IM 12A01G01-03EN	Online manual
FLXA402T Liquid Analyzer for Turbidity and Chlorine Operation of pH	IM 12A01G02-01EN	Online manual
FLXA402T Liquid Analyzer for Turbidity and Chlorine Operation of SC	IM 12A01G03-01EN	Online manual

"EN" in the document number is the language code.

An exclusive User's Manual might be attached to the products whose suffix codes or option codes contain the code "Z" (made to customers' specifications). Please read it along with this manual.

Technical Information

Contents	Document number	Note
FLXA402T Liquid Analyzer for Turbidity and Chlorine MODBUS Communication	TI 12A01G01-62EN	Online manual

"EN" in the document number is the language code.

You can download the latest documents from our website. Scan QR code.

<http://www.yokogawa.com/an/flxa402t/download/>



Refer to each corresponding manual for other related products.

■ Notes on Handling User's Manuals

- Please hand over the user's manuals to your end users so that they can keep the user's manuals on hand for convenient reference.
- Please read the information thoroughly before using the product.
- The purpose of these user's manuals is not to warrant that the product is well suited to any particular purpose but rather to describe the functional details of the product.
- No part of the user's manuals may be transferred or reproduced without prior written consent from YOKOGAWA.
- YOKOGAWA reserves the right to make improvements in the user's manuals and product at any time, without notice or obligation.
- If you have any questions, or you find mistakes or omissions in the user's manuals, please contact our sales representative or your local distributor.

■ Drawing Conventions

Some drawings may be partially emphasized, simplified, or omitted, for the convenience of description.

Some screen images depicted in the user's manual may have different display positions or character types (e.g., the upper / lower case). Also note that some of the images contained in this user's manual are display examples.

■ Terminology

Chlorine sensor analyzer or (the) analyzer	RC800D + FLXA402T
the sensor unit or the sensor	RC800D
(the) converter or (the) liquid analyzer	FLXA402T

■ Trademark Acknowledgements

- FLEXA, FLXA and SENCOM are trademarks or registered trademarks of Yokogawa Electric Corporation.
- All other company and product names mentioned in this user's manual are trademarks or registered trademarks of their respective companies.
- We do not use TM or ® mark to indicate those trademarks or registered trademarks in this user's manual.

RC800D
Reagent Type
Residual Chlorine Sensor Unit

IM 12F04B10-02EN 10th Edition

CONTENTS

- ◆ **INTRODUCTION.....i**
- 1. OVERVIEW 1-1**
 - 1.1 Configuration of the residual chlorine analyzer..... 1-2
 - 1.2 Part Name and Functions 1-4
 - 1.3 Specifications..... 1-5
 - 1.4 Model and Codes 1-6
 - 1.5 Dimensions..... 1-10
 - 1.6 Measuring Principle of RC800D 1-11
- 2. INSTALLATION, WIRING 2-1**
 - 2.1 Installation 2-1
 - 2.1.1 Installation Site..... 2-1
 - 2.1.2 Mounting 2-1
 - 2.2 Piping 2-2
 - 2.2.1 Sample Water Piping 2-6
 - 2.2.2 Reagent Piping 2-6
 - 2.2.3 Cleaning Water Piping 2-6
 - 2.2.4 Drain Piping..... 2-6
 - 2.2.5 Purge Air Piping 2-6
 - 2.2.6 Standard Solution Piping 2-7
 - 2.2.7 Automatic Zero Calibration Piping 2-7
 - 2.3 Wiring 2-8
 - 2.3.1 Wiring of the power supply and the grounding 2-11
 - 2.3.2 Wiring Contact Input/Output, mA input/output, Digital communication. 2-12
- 3. Preparation for OPERATION 3-1**
 - 3.1 Inspecting Piping and Wiring 3-1
 - 3.2 Preparation of reagents..... 3-1
 - 3.3 Condition check of the Chlorine Sensor Unit 3-2
 - 3.4 Filling beads 3-2
 - 3.5 Checking sand filter..... 3-3
 - 3.6 Supplying samples 3-3
 - 3.7 Supplying the cleaning water 3-3
 - 3.8 Polishing measurement electrode 3-3
 - 3.9 Supplying power and switching to maintenance mode 3-3
 - 3.10 Checking pump delivery rate..... 3-4
 - 3.10.1 Checking a sample flow rate..... 3-4
 - 3.10.2 Checking reagent quantity 3-4
 - 3.11 Verifying operation of the Measurement electrode..... 3-5
 - 3.12 Checking the solenoid valve for cleaning and the opening of the ball valve 3-6

3.13	Supplying purging air.....	3-6
3.14	Filling zero water and Test operation (for auto zero calibration).....	3-7
3.15	Setting Operation Parameters.....	3-7
3.16	Calibration.....	3-7
3.17	Switching to measurement mode.....	3-7
4.	Setting parameters.....	4-1
4.1	Measure setting.....	4-2
4.1.1	Negative value non output.....	4-2
4.1.2	Chlorine unit/Temperature unit.....	4-2
4.1.3	Meas./Maint. damping time constant.....	4-2
4.1.4	Applied-voltage Compensation.....	4-3
4.1.5	Chlorine warning High/Low limit.....	4-3
4.1.6	Electrode rotating speed.....	4-3
4.1.7	Compensation setting.....	4-3
4.2	Calibration/Maintenance settings.....	4-3
4.2.1	Stability check.....	4-3
4.2.2	Temp. offset.....	4-3
4.2.3	Wash/Cal. box.....	4-3
4.2.4	Plateau data acquisition set.....	4-4
4.2.5	Calibration setting others.....	4-4
4.3	Diagnosis setting.....	4-4
4.3.1	Empty cell detection.....	4-4
4.3.2	Signal status.....	4-4
4.3.3	Operation days.....	4-5
4.4	Communication setting.....	4-5
4.5	Auto Wash/Calibration setting.....	4-5
4.5.1	Auto sequence for wash/cal.....	4-5
4.5.2	Start date.....	4-5
4.5.3	Wash/Calibration On/Off.....	4-5
4.5.4	Auto sequence for wash/cal.....	4-6
5.	FLXA402T sensor menu.....	5-1
5.1	WASH.....	5-2
5.2	Calibration.....	5-2
5.3	Detail.....	5-3
5.4	Reset op. time.....	5-5
5.5	Sensor setting menu.....	5-5
5.6	Maintenance menu.....	5-6
5.6.1	Maintenance mode.....	5-6
5.6.2	ME rotating On/Off.....	5-6
5.6.3	SV manual operation.....	5-6
5.6.4	Plateau data acquisition.....	5-7
5.6.5	Pump flow rate measuring.....	5-8
6.	OPERATION.....	6-1
6.1	Measurement of Residual chlorine.....	6-1
6.2	Empty cell detection.....	6-1
6.3	Automatic wash/Automatic calibration Operation.....	6-1
6.4	Stop and restarting operation.....	6-1
7.	CALIBRATION.....	7-1

7.1	Zero Calibration.....	7-1
7.2	Slope calibration	7-2
7.3	Auto zero calibration	7-3
7.4	2 points correction.....	7-3
7.5	Basic (reference) sensitivity calibration.....	7-4
7.6	Zero calibration with circuit open	7-4
7.7	Calibration Error.....	7-4
8.	MAINTENANCE.....	8-1
8.1	Replenishment of reagent.....	8-1
8.2	Polishing the measurement electrode	8-2
8.3	Lubrication of the liquid flow pump drive	8-3
8.4	Calibration	8-3
8.5	Cleaning the Beads and Flow cell.....	8-4
8.6	Checking the electrode unit, Replacing Parts.....	8-5
8.6.1	Replacement of Rotating contact	8-5
8.6.2	Maintenance/ Replacement of Driven Shaft Assembly	8-8
8.6.3	Maintenance/Replacement of Motor/Coupling.....	8-10
8.7	Replacement of valve sheet and Bellofram in the liquid flow pump.....	8-10
8.7.1	Replacement of bellofram.....	8-11
8.7.2	Replacement of the valve sheet	8-12
8.8	Liquid flow pump delivery rate confirmation and adjustment.....	8-13
8.9	Replacement of Activated Charcoal Filter	8-14
8.10	Maintenance of the sand filter	8-15
8.10.1	Inspection of filter sand surface	8-15
8.10.2	Check the amount of filter sand in the sand filter.....	8-15
8.10.3	Inspection of discoloration of filter sand in sand filter	8-15
8.10.4	Replacement of the sand filter	8-16
8.11	Replacement of fuse.....	8-17
9.	TROUBLESHOOTING	9-1
9.1	When an error occurs	9-1
9.2	When No Error Indication Appears	9-3
Appendix	Automatic wash/Automatic calibration Sequence	App-1
	Customer Maintenance Parts List.....	CMPL 12F04B10-01EN
	Customer Maintenance Parts List.....	CMPL 12F04A01-11E
	Revision Record.....	Rev-i

1. OVERVIEW

Chlorine treatment in water treatment systems, such as municipal water supplies, serves to destroy microorganisms, fungi, aquatic plants and shellfish that live in water, and thus to yield appropriate quality for the application. However, adding too much chlorine cause negative effects; in municipal water supplies, it may give the water an unpleasant chlorine odor; in industry, excessive chlorine may corrode plumbing; and in waste water this may release dangerous substances into streams and rivers. For this reason, it has become very important in recent years to use a residual chlorine analyzer when chlorine is added to water, in order to measure the concentration of chlorine, and to monitor and control this concentration.

Residual Chlorine Analyzer composed of RC800D Reagent type Residual Chlorine Sensor Unit and FLXA402T Liquid Analyzer for Turbidity and Chlorine is suitable for process manager and control at water treatment plant or plant/industrial water facility handling coolant or drinking water and for water quality control of large-scale boilers.

RC800D measures free chlorine or total chlorine by amperometric principle. It employs a polarographic method by rotating gold alloy electrode to provide continuous online measurement. By appropriate use of reagents, RC800D offers chlorine measurement system featuring separation performance between residual chlorine measurement (free chlorine plus combined chlorine) and free chlorine measurement.

FLXA402T a next-generation analyzer is designed, being tailored from the well-received FLXA402 technical, to provide analysis with user-friendly color HMIs and digital communications.

The technology of predictive maintenance prevents accidental shutdown of the factory. These functions help to reduce OPEX. RC800D has drastically improved maintainability and minimized the maintenance time.

1.1 Configuration of the residual chlorine analyzer

The RC800D is used with FLXA402T Liquid Analyzer for Turbidity and Chlorine.

● RC800D Reagent Type Residual Chlorine Sensor Unit

The RC800D, built into a stanchion, measures the concentration of residual chlorine. The following are also attached to the stanchion:

- Flow cell: Sample flows
- Electrode unit: Electrode and motors are incorporated
- Smart unit: Memory of parameters, control unit
- Liquid flow pump
- Relay box
- Terminal box
- Solenoid valve, strainer, sand filter, air pump, etc. (depending on the specifications)

The overall configuration is roughly divided into Measurement system, Sampling system, and Air piping system.

Depending on the specifications of the sampling device, cleaning piping system or automatic zero piping system is also incorporated.

<Measurement system>

The measurement system includes the Electrode unit, Flow cell, and Smart unit. The Electrode unit is composed of electrode rotation mechanisms such as electrodes and motors.

The Flow cell has an overflow structure, where a mixed solution of samples and reagents is passed through.

The Smart unit is equipped with an AD conversion function and parameter storage function.

<Sampling system>

The sampling system includes sample piping and reagent piping.

The samples and reagents which are sent to the Flow cell of the detector are adjusted to the specified flow rate in this sampling system.

Ball valves, head tanks (for water purification and distribution), sand filters, and liquid flow pumps are incorporated in the sample piping.

The sand filter removes iron ions and manganese ions, which have the property of liberating flocs and iodine that pollute the electrodes, from the sampled measurement water.

<Air piping system>

The "air piping system" consists of piping for air purging.

The purging air piping is provided to prevent parts such as the electrode unit and pump drive mechanism from being corroded by the halogen gas generated from the samples. Thereby clean and dry air can be supplied.

For specifications with an air pump, an air pump is installed for purging.

If no air pump is installed, connect an air source such as instrumented air via a Pressure regulator.

<Cleaning piping system>

The cleaning piping system used when the sampling device specifications are "-2 □" or "-3 □" has the function of cleaning the filter sand, Flow cell, and glass beads in the sand filter, and removing and discharging flocs.

Cleaning is performed automatically by opening and closing the solenoid valve built into the cleaning water pipe with the sequence signal from the FLXA402T. The cleaning water pipe also incorporates a Pressure regulator that regulates the pressure of the cleaning water.

<Automatic zero calibration piping system>

The residual chlorine meter with automatic zero calibration performs zero calibration using an activated charcoal filter. Automatic zero calibration is performed by opening and closing the solenoid valve SV3 with the sequence signal from FLXA402T.

● **FLXA402T Liquid Analyzer for Turbidity and Chlorine (converter)**

The FLXA402T Liquid Analyzer for Turbidity and Chlorine output/displays measurement or status of connected sensors.

Refer to IM 12A01G01-03EN for setup of display, input/output, or communication.

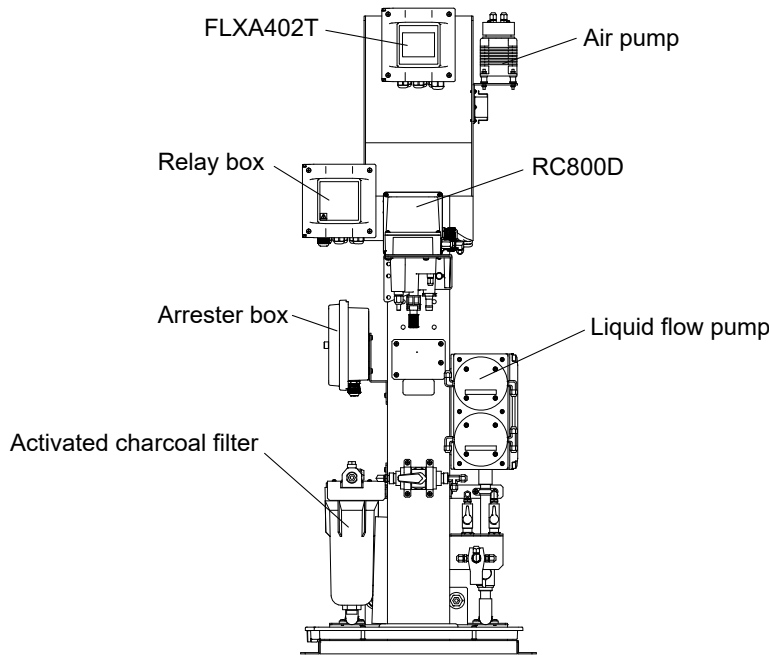

Figure 1.1

1.2 Part Name and Functions

For FLXA402T Liquid Analyzer for Turbidity and Chlorine, see FLXA402T Operation of Converter IM 12A01G01-03EN.

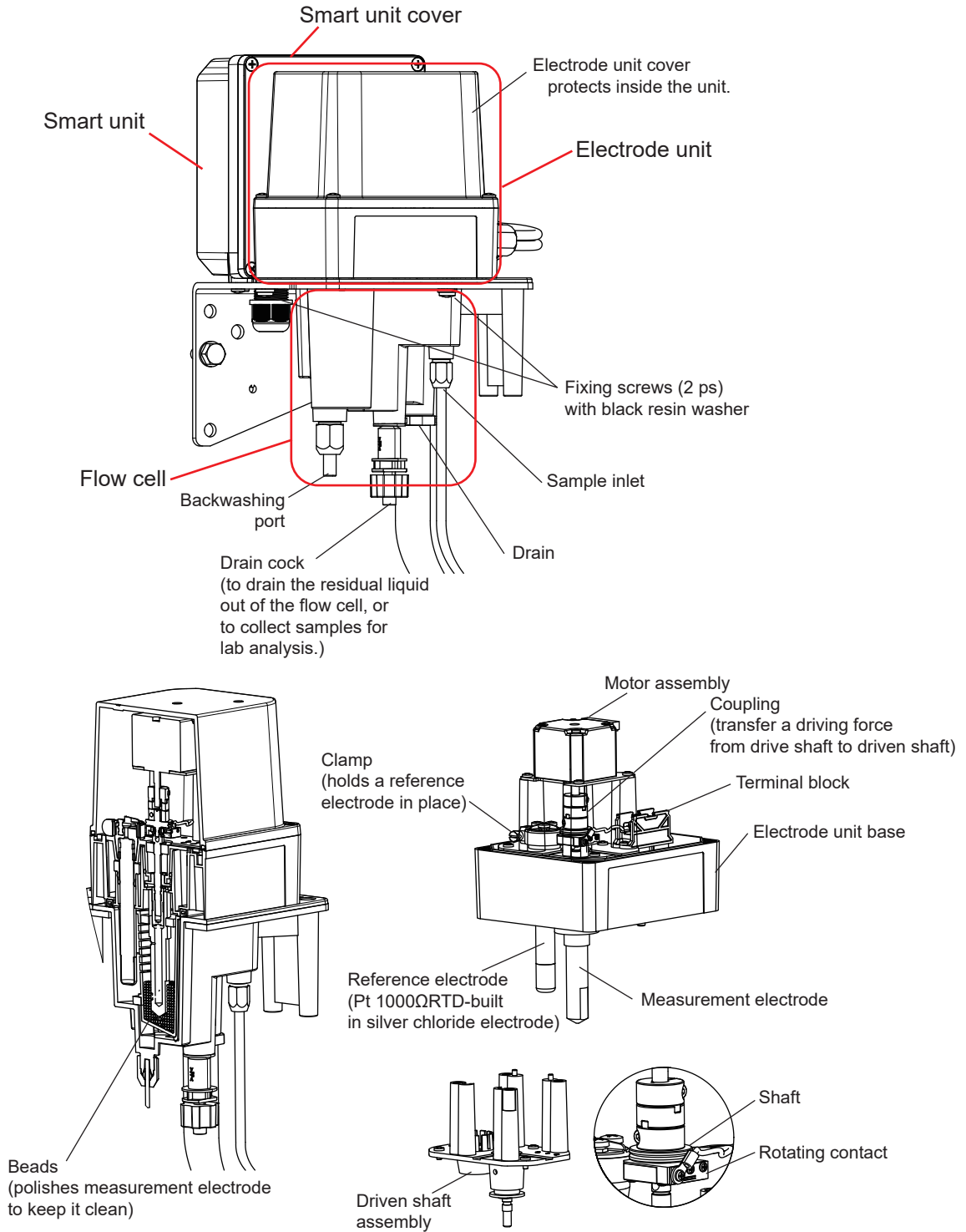

Figure 1.2 RC800D Parts and Functions

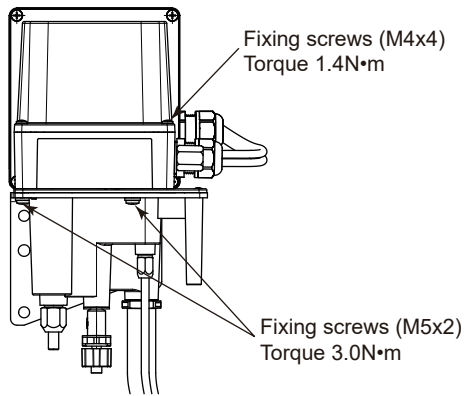

Figure 1.3 Measurement position

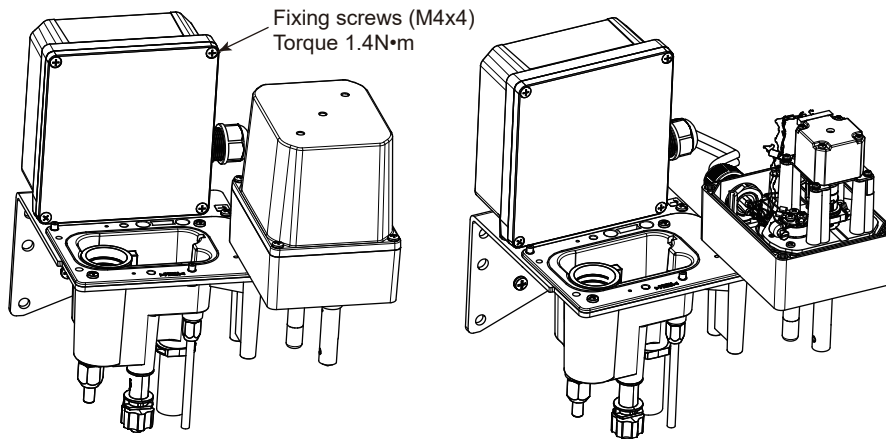

Figure 1.4 Maintenance position

1.3 Specifications

See the RC800D General Specification, GS 12F04B10-01EN.

1.4 Model and Codes

RC800D Reagent Type Residual Chlorine Sensor Unit

Model	Suffix code	Option code	Description
RC800D	Reagent Type Residual Chlorine Sensor Unit
Measurement object (*1)	-F	Free Available Chlorine (Free Chlorine)
	-C	Combined Chlorine Insensitive Version (Free Chlorine) (*2)
	-T	Residual Chlorine (Total Chlorine)
Type	-AB	General purpose for RCM, CE, China standard (*6)
	-AD	General purpose for CSA (*6) (*7)
	-AG	General purpose for KC
	-AJ	General purpose
Sampling system (*3)	-1N	For tap water/water distribution measurement (without sand filter)
	-2N	For raw water measurement One Sand Filter, with auto.cleaning
	-3N	For raw water measurement DBL sand filter, with auto.cleaning
	-1A	For tap water/water distribution measurement with auto.Zero calibration (without sand filter)
	-2A	For raw water measurement One Sand Filter with auto.Zero calibration
	-3A	For raw water measurement DBL sand filters with auto.Zero calibration
Stand material	-AB	Carbon steel stanchion
	-SB	Stainless steel stanchion
Sampling Power supply	-10	100V AC, 50Hz
	-11	100V AC, 60Hz
	-12	110V AC, 50Hz
	-13	110V AC, 60Hz
	-22	220V AC, 50Hz
	-23	220V AC, 60Hz
Pump for Purging Air (*4)	-NA	Without pump for Air Purge
	-P1	Pump for Purging Air (100V, 50/60 Hz)
	-P2	Pump for Purging Air (110V, 50/60 Hz)
	-P4	Pump for Purging Air (220V, 50/60 Hz)
—	-NN	Always -NN
—	-NN	Always -NN
Option	/SCT	Stainless Steel Tag Plate
	/CB3	Conduit adapter G1/2 x 3 pcs (*8)
	/CD3	Conduit adapter 1/2 NPT x 3 pcs (*8)
	/CF3	Conduit adapter M20 x 1.5 x 3 pcs (*8)
	/ARS	With Arrestor
/NR	Without reagent set for start-up (*5)	

*1: Measurement object selection is indicated in the following.

Application	Measurement object	
	Free chlorine	Total chlorine
Water purification: raw water	√ (*a)	√
Water purification: mixed water, sedimentation water	√ (*a)	√
Water purification mains water	√	√
Factory wastewater, treated effluent	N/A	N/A
Factory cooling water (industrial water)	N/A	√ (*b)
Factory drinking water	√	√

√ : Can be measured, N/A: Cannot be measured

*a: If ammoniacal contaminants are present in large quantity, high concentrations of combined chlorine may remain if sampling is performed soon after chlorine injection in prechlorination treatment, or in intermediate treatment without prechlorination treatment. In this case, combined chlorine type is recommended.

*b: Oxidizing or reducing agents other than chlorine may be present. If so, chlorine concentration measurement may not be possible.

*2: Less affected by combined chlorine in free chlorine measurement.

*3: Please contact Yokogawa regarding the adequate number of the sand filter.

*4: Installation of Purging Air is required for all application. If instrument air cannot be used, select a Pump for Purging Air. Select the one with same voltage as sampling power supply.

*5: When ordering the RC800D, select /NR and get reagent sets for start-up from local reagent supplier. These reagent sets can not be exported from Japan due to both safety and transportation issues.

*6: When you select "-AB" or "-AD" and use sampling power of 100V or 110V, you cannot use any pump for purging air. Conduct purging with an instrument air.

*7: When you select "-AD" (CSA), "/ARS" cannot be selected.

*8: See "● Required number of conduit adapters" of GS 12F04B10-01EN. The connection of power supply uses 1 conduit. After completing conduit work on RC800D, you can use the unused conduit adapters for the conduit of FLXA402T.

● Accessories

Name	Q'ty	Parts No.	Remarks
Polishing powder (Alumina)	1 Bottle	K9088PE	For polishing electrode
Lubricant	1	K9041RA	For Liquid flow pump drive
Glass beads	1	K9332ZJ	2 bags / 1 Q'ty (including spare)
Valve sheet	4	K9041HC	For Liquid flow pump (for spare)
Bellofram	1	K8004YY	For sample pump (for spare)
	1	L9819AA	For reagent pump (for spare)
Tool	1	K9041SK	For Valve sheet replacement
Hardware for Bellofram	1 set	K9041SW	For Bellofram replacement
Allen wrench	1 set	L9827AB	Nominal size: 1.5 mm
		L9827AC	Nominal size: 2.5 mm
		L9827AD	Nominal size: 4 mm
		L9827AE	Nominal size: 5 mm
		L9827AF	Nominal size: 6 mm
		L9827AT	Nominal size: 2 mm

● Spare Parts

Table 1.1 Spare parts

The recommended replacement cycle indicates a guideline for replacement, and does not guarantee this period.

Name	Part No.	Description	Recommended replacement interval
Measurement Electrode (rotating electrode)	K8005JC	Gold alloy electrode	Yearly
Reference Electrode	K8005UH	Platinum electrode (-F, -T)	when damaged
Reference electrode	K8005UC	Silver/Silver chloride electrode for combined chlorine insensitive type, (-C)	when damaged
Glass Beads	K9332ZJ	2 packs / piece	Yearly
Rotating contact	K9332SR	Part for the electrode unit	Yearly
Driven shaft assembly	K8005LB	Part for the electrode unit	3 years
O-ring	Y9115XB	Part for the electrode unit	3 years
Motor	K8005LC	Part for the electrode unit	3 years
Coupling	B1005AC	Part for the electrode unit	3 years
Fuse	A1633EF	250V/2.5A for the smart unit	—
Fuse	A1624EF	250 V/3.15 A for the relay box The relay box uses two fuses.	—
Sand for filter	K9720FZ	1 L for the sand filter (-2N,-3N,-2A,-3A)	Yearly
Air pump (100V)	K9087XA	For the Air pump (-P1)	3 years
Air pump (110V)	K9087XF	For the Air pump (-P2)	3 years
Air pump (220V)	K9087XH	For the Air pump (-P4)	3 years
Lubricating oil	K9041RA	For liquid pump monthly maintenance	1 month *
Bellofram	L9819AA	For reagent flow control of liquid pump	6 Months
Bellofram	K8004YY	For sample flow control of liquid pump	6 Months
Valve sheet	K9041HC	For Liquid flow pump RC800D has 2 liquid flow pumps.	6 Months
	K9041SU	4 pcs of K9041HC	
Activated charcoal filter	L9862AY	For zero calibration	Yearly
Filter	K9332NN	Parts of the sand filter (-2N,-3N,-2A,-3A)	Yearly

*: Recommended replacement interval is for preventive maintenance, although parts may be used longer than those period described.

● Measurement electrode (K8005JC)

The surface of measurement electrode is susceptible to abrasion by constant beads polishing. To use the measurement electrode for a long time, annual replacement is recommended.

However, accidental damage or other factors can cause defects, so we recommend keeping always one spare available.

NOTE: For the use of spare parts, refer to the following "Applying Electrically conductive Silicon Grease to measurement Electrode".

[Applying Electrically conductive Silicon Grease to Measurement Electrode]

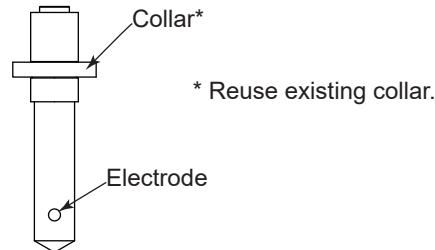

The measurement electrode needs to be electrically connected to the driven shaft.

This is achieved by applying electrically-conductive silicon grease to the tapped part of the measurement electrode.

Before use, check that this has been done. If not, apply silicon grease as follows.

You can purchase 3 mL bottle of conductive silicon grease from Yokogawa, the part no. is K9044FX.

- Be careful not to get this grease on the outer surface, particularly the gold alloy surface.
- Apply a small quantity (half a drop) of grease to a small flat screwdriver (about 3 mm wide blade) and apply to three equidistant places around the tapped hole, about 3 to 5 mm inside the tip.
- Screw the measurement electrode with this tapped (threaded) hole to driven shaft. . Next unscrew the electrode and check that no grease has been extruded to the outer surface. If it has, remove it with a cloth that has been wetted with alkaline soap solution.
- You only need to apply the conductive silicon grease once.

● Reference electrode (K8005UC or K8005UH)

The reference electrode does not wear like the measurement electrode; it can be continuously used without replacement.

However, we recommend keeping one spare always available, in case of accidental breakage.

● Beads (K9332ZJ)

Beads used for polishing measurement electrodes are worn in long-term use, thereby reducing the ability to polish measurement electrodes. The replacement interval depends on the condition of operation.

However, as standard intervals, they should be replaced one or two times a year.

As standard spare parts, 1 case (2 packs/case) is supplied with the product.

● Polishing Powder (K9088PE)

Automatic polishing with beads does not completely prevent adhesion of accumulated contamination. You regularly need to polish out the left contamination manually with the polishing powder (alumina).

One bottle of the polishing powder is supplied with the product.

- **Rotating contact (K9332SR)**

 **CAUTION**

Do not touch the rotating contact except when replacement is performed.

The rotating contact is in a mechanism consisting of brush and ring together that obtain signals. It becomes worn out over a long period of continuous use. The lubricant used for the part also needs to be concerned about its quality degradation after a long period of use. Therefore, the standard replacement interval is one year.

See "8.6.1 Replacement of Rotating contact" for the replacement procedure.

CAUTION

The storage limit for the rotating contact is one year after the purchase, considering the degradation of the lubricant used inside. Store it at a normal temperature and keep it away from direct sunlight.

- **Driven Shaft Assembly (K8005LB)**

The two bearings on the driven shaft assembly ensures a smooth rotation of the rotating shaft.

The bearings will be worn gradually. They should be replaced after approximately three-year operation.

Replacement should in principle be performed by Yokogawa.

See "8.6.2 Maintenance/ Replacement of Driven Shaft Assembly" for replacement procedure.

- **Motor Assembly (K8005LC)**

It is an assembly in which the motor and the sheet metal for mounting are assembled. The rotating parts wear out. Replace it about once every 3-year operating time.

Refer to "8.6.3 Maintenance/Replacement of Motor/Coupling".

- **Coupling (B1005AC)**

Three-layer structured cylindrical component connects a driven shaft assembly to the motor shaft. Refer to Section "8.6.3 Maintenance/Replacement of Motor/Coupling" for the replacement procedure.

- **Activated Charcoal Filter (L9862AY)**

Used when auto zero calibration is enabled. Replace the filter about once a year.

- **Fuse (A1633EF, A1624EF)**

Yearly replacement is recommended to avoid unexpected operation stoppage.

- **Lubricating oil (K9041RA)**

To maintain smooth operation of the metering pump drive assembly levers, use this lubricating oil on each bearing of the four lever support blocks once a month or so. One bottle of lubricating oil is supplied as an accessory. It can be used for some time as its use requires only about 0.4 mL at one time.

- **Sand (K9720FZ)**

This is a spare part required for raw water type and treated water type analyzers, and used in the following situations.

- (1) When sand in the sand filter has decreased.

Flocks, etc. depositing in the sand filter are flushed and discharged from the sand filter by automatic water jet at regular intervals. If the frequency of the automatic cleaning is improper, sand can be discharged with the flocks, and sand in the sand filter decreases. As the sand filter must retain sand to a certain level, making-up for sand decrease is required.

- (2) When the entire sand in the sand filter has discolored.

Although manganese and iron contained in sample water are contaminants of the electrodes, sand adsorbs most of the metals in the sample water, minimizing the contamination of the electrodes.

When the sand has adsorbed a quantity of metals such as to discolor the entire sand layer, the sand loses adsorption power and needs to be freshly replaced.

- **Valve Sheet (K9041HC)**

It is recommended to replace the valve sheets on the suction and delivery sides of sample water and reagent metering pumps after use for six months to prevent possible trouble even if the sheets still show no defect.

Determine the quantity of spare valve sheets taking this scheduled replacement into account.

- **“Bellofram” (L9819AA, K8004YY)**

“Bellofram” used in the piston sections of the metering pumps should be replaced after six months use even if no defect has developed, as is the case with the valve sheet. “Bellofram” for the sample water metering pump and that for the reagent metering pump have different sizes.

- **Activated Charcoal Filter (L9862AY)**

To secure accurate zero value, it is recommended that the filter be replaced once a year.

- **Filter (K9332NN)**

It is recommended that the filter which used for head tank or sand filter be replaced once a year.

1.5 Dimensions

See the latest specifications of the product, GS 12F04B10-01EN.

1.6 Measuring Principle of RC800D

The object of measurement of "RC800D residual chlorine sensor" is free chlorine (Free available chlorine), or the total residual chlorine (total residual chlorine) containing free chlorine and combined chlorine.

Free chlorine is in the form of chlorine (Cl₂), hypochlorous acid (HClO), and hypochlorite ion (ClO⁻) in water.

Combined chlorine exists in the form of chloramines such as trichloramine (NCl₃) and dichloramine (NHCl₂), which are formed by the reaction of chlorine with ammoniacal nitrogen contained in rivers due to pollution, etc.

The residual chlorine meter is based on the rotational electrodes polarographic method, and the amount of free chlorine or total residual chlorine-containing combined chlorine in free chlorine is measured by selectively using reagents, electrodes, and applied voltages.

The total residual chlorine is measured by adding potassium iodide (KI) to the measuring water to react with chlorine.

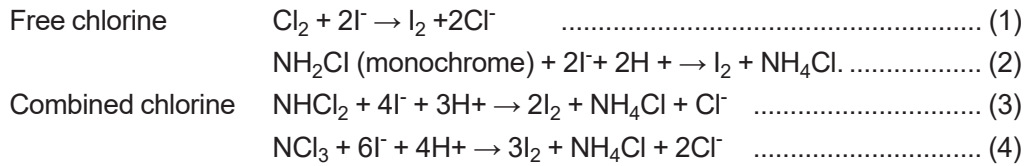

These free iodines are electrolytically reduced by applying an external voltage between the measurement electrode and the reference electrode. The flowing current is measured to determine the iodine concentration (indirectly chlorine concentration).

For this reason, the applied voltage is chosen as the value at which the concentration polarization occurs in the so-called polarography, where current value does not change even if the voltage value changes.

For measurement of total residual chlorine, -0.40 V is applied.

The diffusion current obtained under this condition is approximately 2.0 μA/ (mg/L) based on the 20°C sample as criteria.

It has a temperature factor of approximately 2%/°C in the range of 0 to 40°C.

The effect of the temperature factor on the measured value is removed from the temperature sensor (RTD) (Pt1000) arithmetic that is built into the comparator.

The reagent serves as a pH buffer solution by using acetic acid and sodium acetate in addition to potassium iodide, and helps RC800D to detect all chlorine by keeping the sample pH below 4.5.

The amount of free chlorine is measured by adding potassium bromide (KBr) to the sample, as shown in equation (5) to make it react with chlorine to liberate bromine.



Other than releasing bromine, the measurement method of the free chlorine has no difference from the one of total residual chlorine.

Figure 1.5 shows the principles of the measuring circuitry of RC800D residual chlorine meter.

The current flowing between the electrodes is measured by applying a constant voltage between the two electrodes of the measurement electrode and the reference electrode.

Temperature compensation is performed by arithmetic on CPU based on temperature signal from temperature measurement circuit.

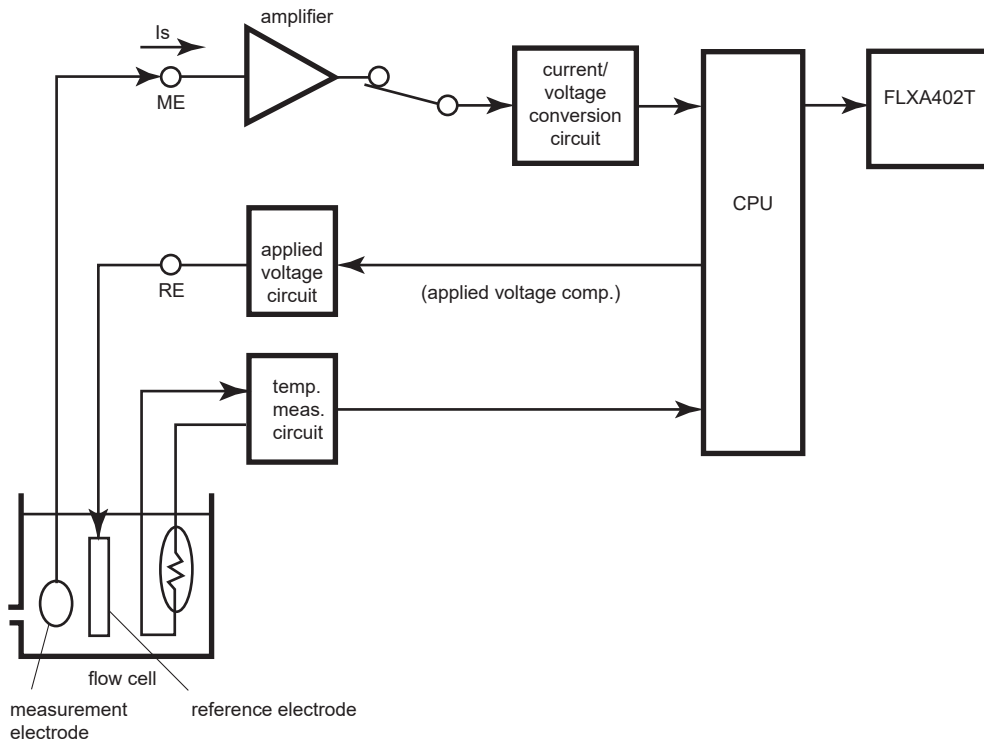

Figure 1.5 Operating principle of the measurement

2. INSTALLATION, WIRING

This chapter describes the procedure for the installation and wiring of RC800D.

RC800D Reagent Type Residual Chlorine Sensor Unit is sufficiently packed for shipment to prevent damage during transportation.

Upon receipt, carefully unpack the RC800D carton near the place of installation.

2.1 Installation

2.1.1 Installation Site

Install the RC800D Reagent Type Residual Chlorine Sensor Unit at a location that

- is free from rain water such as an indoor location or in a cabinet.
- has low vibration.
- has low corrosive gas.
- is low humidity.
- has low temperature variation and is where the temperature is maintained at or as close to room temperature as possible.
- allows sufficient maintenance space with easy maintenance access.
- allows drainage.

2.1.2 Mounting

Securely fix the RC800D to a well-drained "concrete foundation". Refer to "1.5 Dimensions"

When using a reagent tank such as RC401G-A to supply reagents to the RC800D, install the RC800D so that the bottom of the tank is about 70 cm higher than the installation floor of RC800D. For those without a stirrer, make sure the reagent is completely dissolved.

2.2 Piping

Piping for the analyzer is shown below. See individual sections for details.

- 2.2.1 Sample water piping
- 2.2.2 Reagent piping
- 2.2.3 Washing water piping
- 2.2.4 Drain piping
- 2.2.5 Purge air piping
- 2.2.6 Standard solution piping (for calibration)
- 2.2.7 Automatic zero calibration piping

The following (1) to (3) show the flow chart of each analyzer.

**(1) For tap water/water distribution measurement (without sand filter)
(Sampling system: -1N, -1A)**

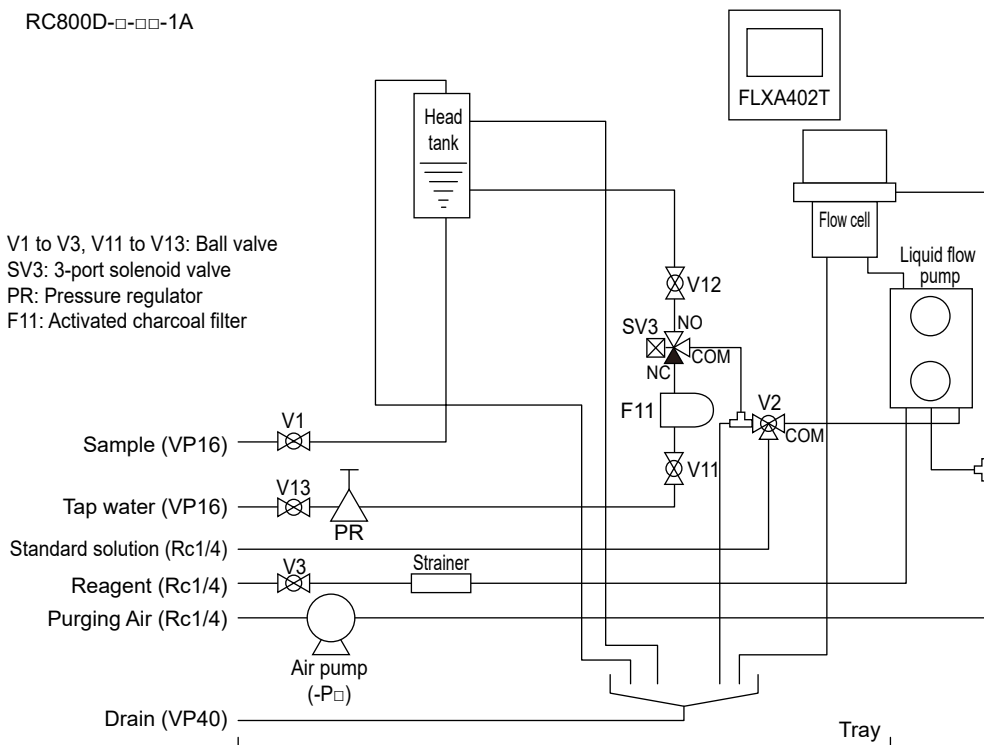
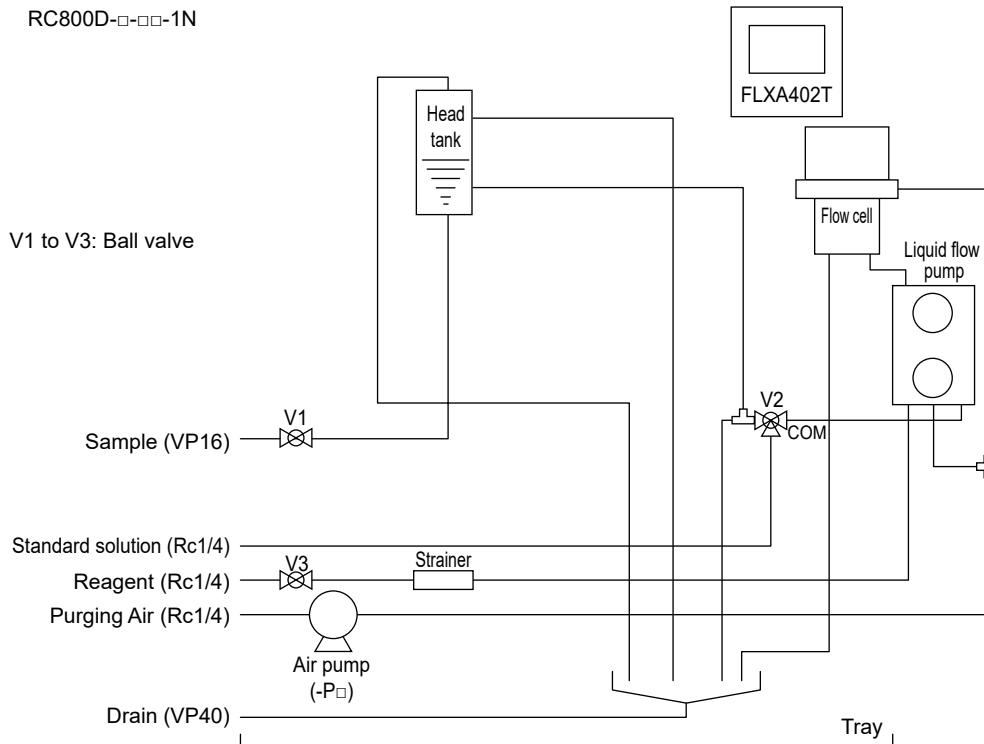

**(2) For raw water measurement One Sand Filter, with auto. cleaning
(Sampling system: -2N, -2A)**

RC800D-□-□□-2N

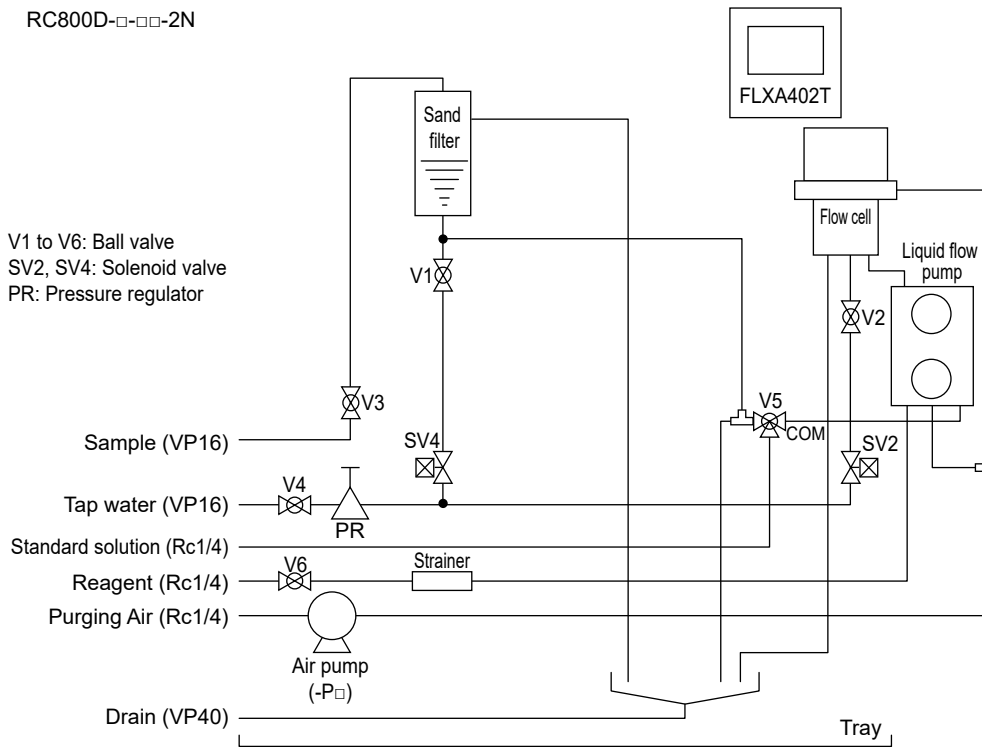

RC800D-□-□□-2A

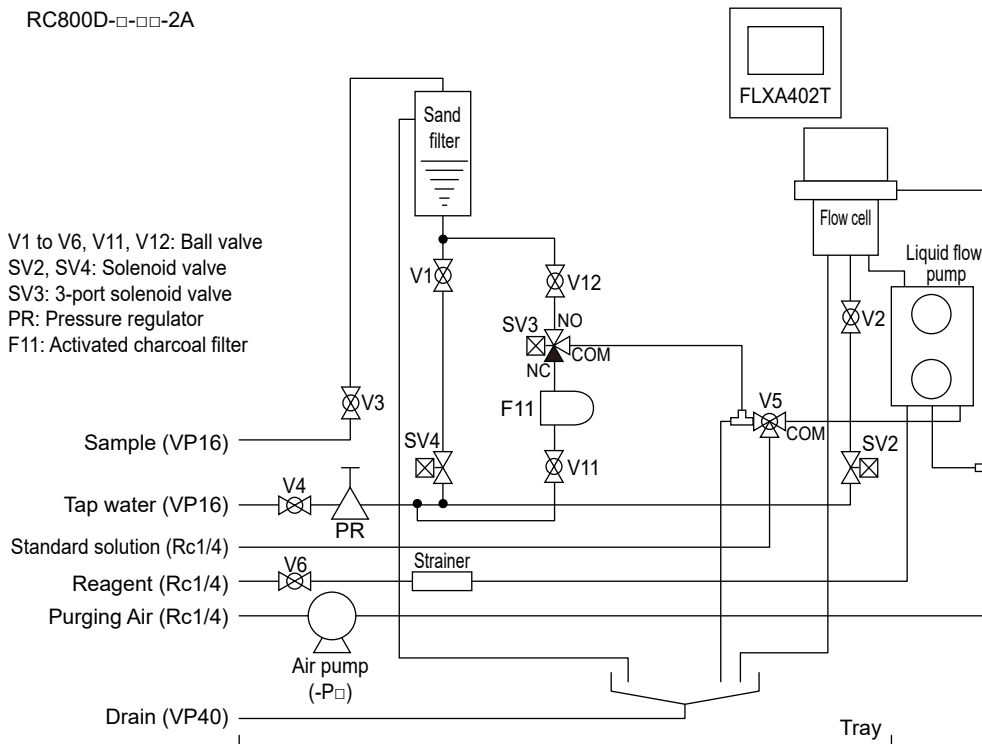

**(3) For raw water measurement DBL sand filter, with auto.cleaning
(Sampling system: -3N, -3A)**

RC800D-□-□□-3N

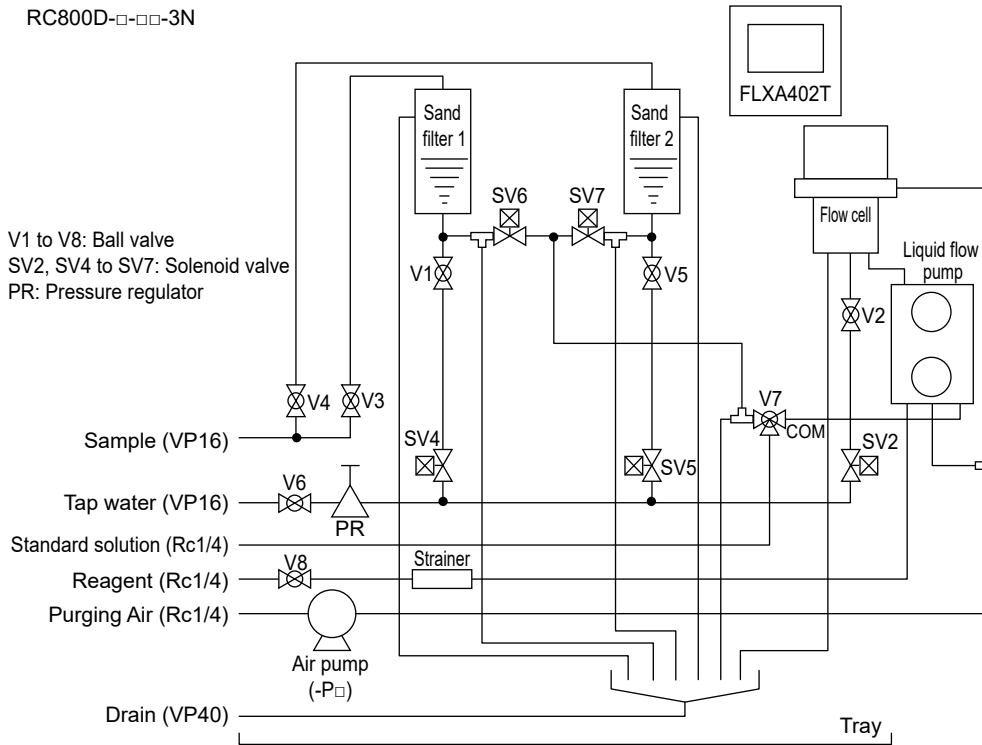

RC800D-□-□□-3A

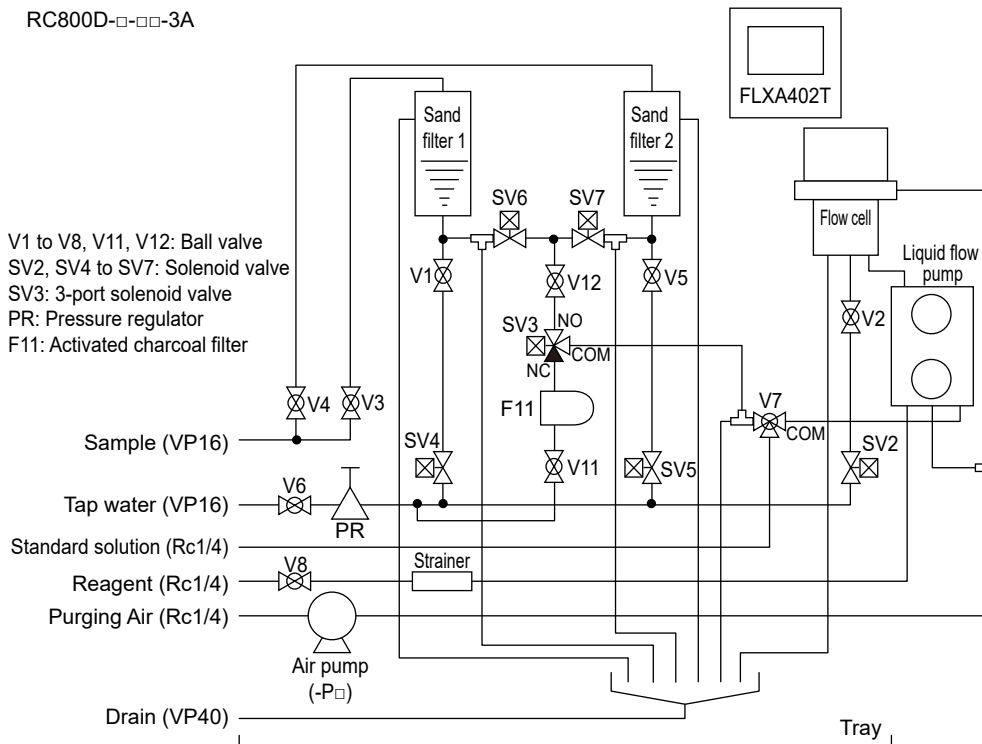

2.2.1 Sample Water Piping

This is the piping for taking sample water and feeding it to the analyzer.

The connection is a rigid PVC tube of nominal dia. 16 (O.D. 22 mm). Implement piping using proper joints, i.e. unions and flanges etc., which fit the connection. Note: Perform piping so that sample water pressure at the connection falls within the range of 20 to 500 kPa.

Sample water flow rates to the analyzer in operation are as follows:

In RC800D-1A, -1N: 1 to 4 L/min

In RC800D-2A, -2N: 5 to 10 L/min

In RC800D-3A, -3N: 10 to 20 L/min

2.2.2 Reagent Piping

Residual chlorine content is determined by sample water mixed with reagent. The reagent piping supplies reagent to the measuring cell of the analyzer.

Connect the outlet of the reagent tank to the reagent inlet of the analyzer using Rc1/4 joint and O.D. 6 mm x I.D. 4 mm polyethylene tube. There is a reagent level limit in the tank. Check that the reagent tank location conforms to the RC401G reagent tank.

2.2.3 Cleaning Water Piping

This piping is required for the raw water type and treated water type analyzers.

In these types of analyzers, intake sample water is filtered by the sand filter. For maintaining filtering capacity, the sand filter is flushed with water at regular intervals to remove floccules, etc. deposited in the filter.

The cleaning water piping leads tap water for washing to the analyzer. The connection is a rigid PVC tube of nominal dia. 16 (O.D. 22 mm).

Perform piping in the same manner as the sample water piping, using proper joints, so as to allow cleaning water pressure to fall within the range of 100 to 500 kPa.

2.2.4 Drain Piping

This is the piping to discharge sample water and cleaning water from the analyzer to a drainage ditch, etc.

The specifications of the piping connections are given below.

In RC800D-1A, -1N: Rigid PVC tube, nominal dia. 40 (O.D. 48 mm)

In RC800D-2A, -2N: Rigid PVC tube, nominal dia. 40 (O.D. 48 mm)

In RC800D-3A, -3N: Rigid PVC tube, nominal dia. 40 (O.D. 48 mm)

Perform piping so as to prevent sedimentation and formation of any dead spot in the piping.

2.2.5 Purge Air Piping

This is the piping to supply clean dry air to the cases which house the converter, electrode mechanism block and pump drive assembly for air purging.

When the RC800D is provided with an air pump, extend the piping to an area free from corrosive gases for intake of clean air. If an air pump is not available, employ instrument air, etc. and perform piping so that air is supplied at a pressure of approx. 140 kPa.

The connection is Rc1/4.

2.2.6 Standard Solution Piping

This supplies standard solution to the analyzer for calibrating zero point or span. Usually, this piping is set up every time when calibration (refer to Chapter 7) is conducted. The piping connection is Rc1/4.

NOTE

Standard solution supplied from the piping connection is directly fed to the metering pump. If the pressure of the supplied standard solution largely exceeds 10 kPa, standard solution may enter the reagent line or some quantity of solution more than specified may be sent to the detector causing the measuring cell to overflow. As a rule, standard solution should be supplied only in the manner described in Chapter 7.

2.2.7 Automatic Zero Calibration Piping

This is the piping that is used when zero calibration using an activated charcoal filter is performed. If the option has been specified, this piping is installed at the factory before shipment.

2.3 Wiring

Wire the power supply, ground wiring, and if necessary, contact input / output, mA input / output, and digital communication wiring. The wiring diagram of RC800D is shown below.

(1) For tap water/water distribution measurement (without sand filter) (Sampling system: -1N, -1A)

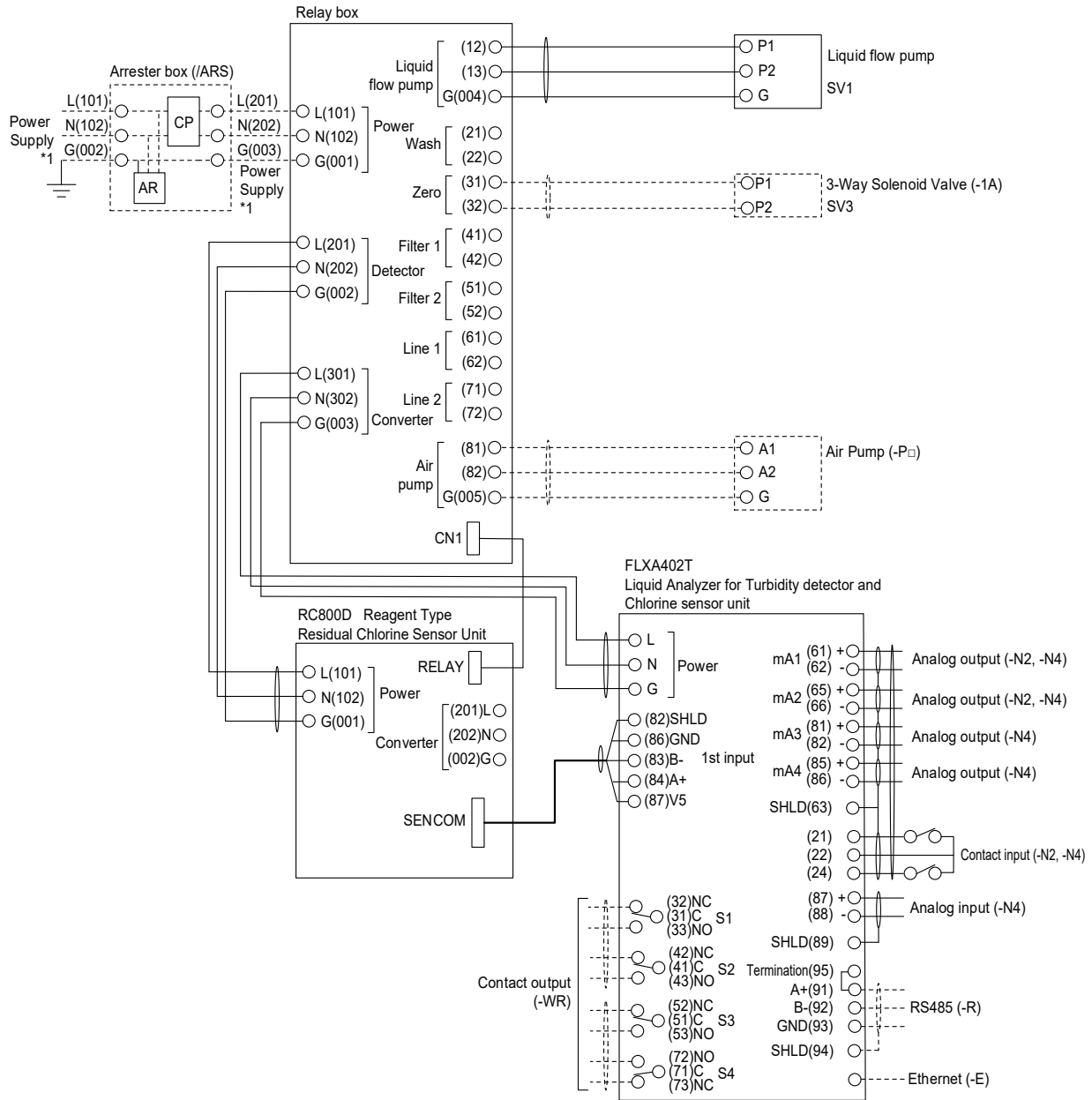

(Note)

*1: Power terminal "G" on Relay box or Arrester box must be grounded (ground resistance: 100 ohm or less).
 In case of selecting /ARS, power supply cable connects with L(101), N(102) and G(001) in Arrester box.
 In case of not selecting /ARS, power supply cable connects with L(101), N(102) and G(002) in Relay box.

(2) For raw water measurement One Sand Filter, with auto. cleaning
(Sampling system: -2N, -2A)

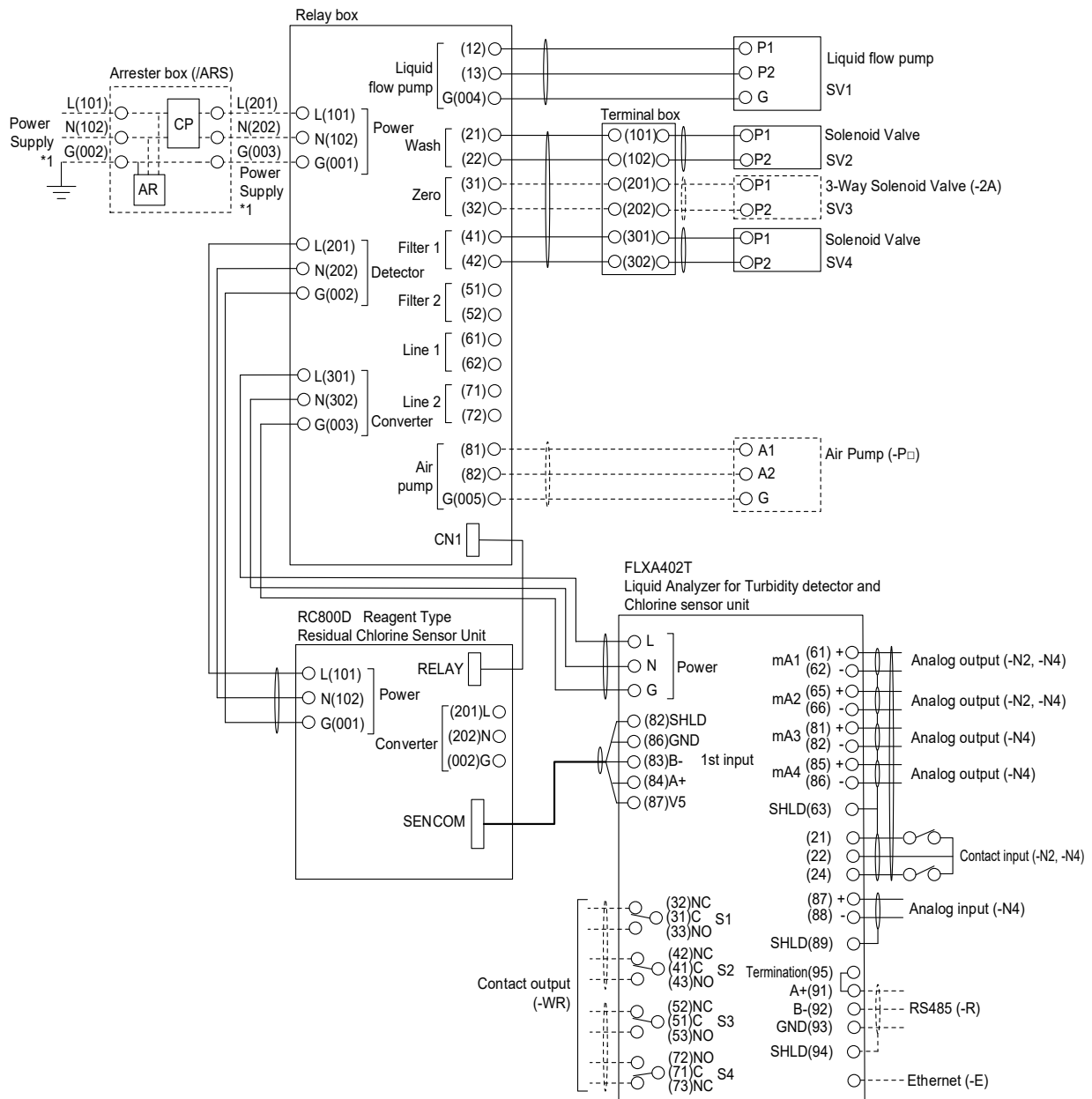

(Note)

*1: Power terminal "G" on Relay box or Arrester box must be grounded (ground resistance: 100 ohm or less).
In case of selecting /ARS, power supply cable connects with L(101), N(102) and G(001) in Arrester box.
In case of not selecting /ARS, power supply cable connects with L(101), N(102) and G(002) in Relay box.

**(3) For raw water measurement DBL sand filter, with auto.cleaning
(Sampling system: -3N, -3A)**

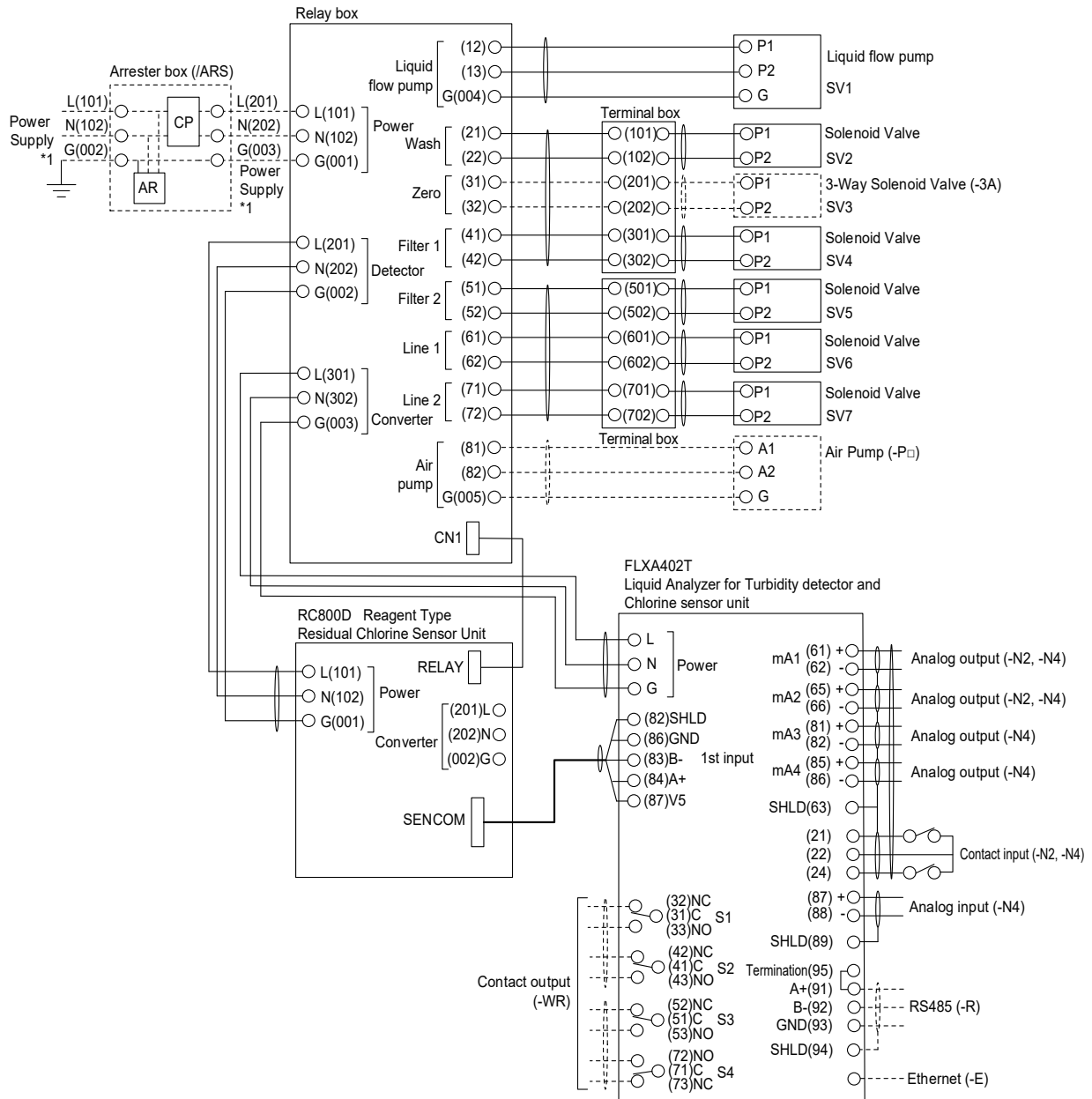

(Note)

*1: Power terminal "G" on Relay box or Arrester box must be grounded (ground resistance: 100 ohm or less).
 In case of selecting /ARS, power supply cable connects with L(101), N(102) and G(001) in Arrester box.
 In case of not selecting /ARS, power supply cable connects with L(101), N(102) and G(002) in Relay box.

2.3.1 Wiring of the power supply and the grounding



WARNING

- You must install external power supply switch or circuit breaker for power supply.
- The external power supply switch or a circuit breaker must comply with a current rating of 5A or IEC60947-1 or IEC60947-3
- Yokogawa recommend installing the external power supply switch, circuit breaker and RC800D converter all in the same location.
- Install the external power supply switch or circuit breaker to the place where operators access easily. To alert users, put a label on the external power switch.
- Fix securely onto constructions or walls all power lines by using cable rack, conduit or vinyl band. Unplugged cables are dangerous and may cause an electric shock.

Table 2.1 Specification of power cable

Rated voltage	300V or above
Rated temperature	75°C or above
Number of cores, Wire diameter	3 L, N, G: 0.75 to 2.5 mm ² (AWG18 to14)
Sheath outer diameter	Ø6.5 to Ø12.5 mm
Cable termination	Strip the outer sheath of 80 mm, provide the termination. L, N: M3 round terminal G: M4 round terminal

■ Without Arrester box (when /ARS is not specified)

Connect the power cable to the terminal shown in Figure 1 inside the Relay box.
RC800D does not have a power switch. Provide a double-sided switch on the power line.
Ground wiring should satisfy class D (ground resistance 100 Ω or less).

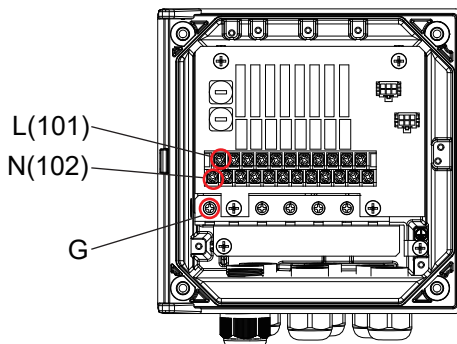

Figure 2.1 Relay box

■ With Arrester box (when /ARS is specified)

Connect the power cable to the terminal shown in Figure 2 inside the Arrester box. Ground wiring should satisfy class D (ground resistance 100 Ω or less).

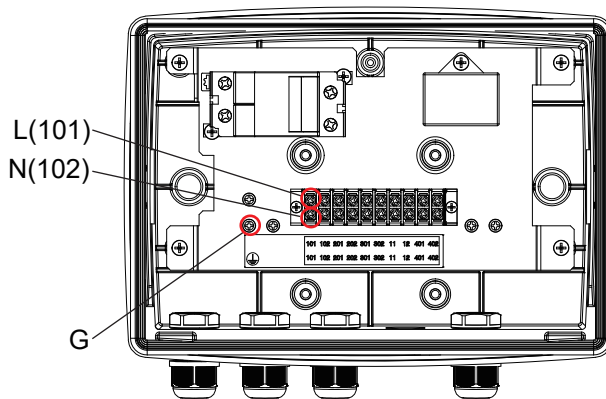

Figure 2.2 Arrester box



WARNING

Use wiring cables with heat resistance above 75°C, waterproof rating IP65 or higher.
Fasten the four screws of Smart unit cover with tightening torque of 1.4 N·m.
For power supply, wire cables with a flammability rating of UL 2556 VW-1 or equivalent.



WARNING

The minimum cross sectional area of the protective grounding wire should be 0.75 mm² - 2.5 mm².
For CSA safety standard (Type: - AD), use cables with a cross section of 0.75 - 2.5 mm².

2.3.2 Wiring Contact Input/Output, mA input/output, Digital communication

The FLXA402T converter is equipped with contact input/output, mA input/output, and digital communication (Modbus TCP / IP or Modbus RTU) functions according to the specifications selected by the customer. Connect these wires inside the FLXA402T. Please refer to the FLXA402T user's manual IM 12A01G01-02EN.

3. Preparation for OPERATION

After the wiring and the piping of the instrument complete properly, first prepare for the operation by following the instruction described in this chapter.

■ Operation mode

Two types as follows are available.

- **Measurement mode**

Steady-state operation takes place.

- **Maintenance mode**

Perform maintenance in this mode. Be sure to turn to this mode before starting calibration or maintenance.

To switch to Maintenance mode, tap  in the main display.
(or Sensor menu > Maintenance > Maintenance mode)

■ Operation in Maintenance mode

Item	Operation
Measurement	Maint. damping time constant applies.
mA output	Output by following the automatic hold setting. Converter menu > Converter setting> mA output setting > Output channels > Auto hold during maintenance
Contact output	Maintenance contact output is ON. Other contact outputs remain the previous value gained right before the Maintenance Mode turned on.
Manual operation	Solenoid valve's manual operation is enabled. To switch to manual operation display, tap  in the Main display. To initialize Valve, turn off the maintenance mode.
Auto wash Auto calibration	not available

3.1 Inspecting Piping and Wiring

Confirm that the piping and wiring have been completed correctly before supplying water or power. Refer to “2.2 Piping” and “2.3 Wiring” for Installation and piping.

3.2 Preparation of reagents

Use different reagents for measurement when measuring free chlorine (“Free” chlorine) and residual chlorine (“Total” chlorine).

When measuring “Total” chlorine, it is necessary to change the amount of components in the reagent depending on the chlorine concentration level of the sample.

Prepare the reagents as follows. Place the prepared reagents in the reagent tank.

- **Preparation of reagents for free chlorine measurement (maximum concentration: 10 mg/L)**

Use “potassium bromide (KBr)” to react with free chlorine in the sample to liberate bromine, “acetic acid (CH₃COOH)” and (CH₃COONa) to keep the pH value of the sample at pH 4.5 to 5.0, and “Sodium acetate” (CH₃COONa).Figure 1.3

When preparing 100 liters of reagent, add 4000 g of primary potassium bromide to approximately 80 liters of pure water.

Dissolve 1000 g of primary sodium acetate and 1000 mL of primary acetic acid (95% or more), and add pure water to make a mixed reagent with a total volume of 100 liters.

Table 3.1 Reagent composition and the amount

Measurement object	Free chlorine
Reagent composition	volume in 100 liters
KBr	4000 g
CH ₃ COONa	1000 g
CH ₃ COOH	1000 mL

Quantity of reagents required for one cycle (about 45 days)
500 g x 8 bottles
500 g x 2 bottles
500 mL x 2 bottles

- Preparation of reagents for free chlorine measurement with combined chlorine insensitive version

Table 3.2 Reagent composition and the amount

Measurement object	Free chlorine
Reagent composition	volume in 100 liters
KBr	4000 g
CH ₃ COONa	5400 g
CH ₃ COOH	200 mL

Quantity of reagents required for one cycle (about 45 days)
500 g x 8 bottles
500 g x 11 bottles
500 mL x 1 bottle (can be used twice)

- Preparation of reagents for total chlorine measurement

As reagents, use “potassium iodide (KI)” that reacts with chlorine in the sample to release iodine, “acetic acid (CH₃COOH)” and “sodium acetate” (CH₃COONa) to keep the pH value of the sample at a constant value of pH 4.5 or less.

The amount of potassium iodide used depends on the concentration of residual chlorine. See Table 3.3.

Table 3.3 Reagent composition and the amount

Measurement object and maximum concentration	Residual chlorine	
	up to 6 mg/L	over 6 to 10 mg/L
	Volume in 100 liters	
KBr	500 g	1000 g
CH ₃ COONa	150 g	
CH ₃ COOH	1000 mL	

Quantity of reagents required for one cycle (about 45 days)	
up to 6 mg/L	over 6 to 10 mg/L
500 g x 1 bottle	500 g x 2 bottles
500 g x 1 bottle (can be used 3 times)	
500 mL x 2 bottles	

3.3 Condition check of the Chlorine Sensor Unit

Be sure that the drain cock is closed.

To prepare for the operation, place the electrode unit in a measurement position (Figure 1.3) or maintenance position (Figure 1.4).

3.4 Filling beads

Pour beads into the beads case before starting the RC800D.

[How to fill beads into the case]

Loosen the two Electrode unit fixing screws. Set the Electrode unit in a maintenance position (Figure 1.3).

Fill the beads (accessory) into the bead case. Place the Electrode unit back to the measurement position. Check that the appropriate amount of beads are filled in the case and fasten the fixing screws to hold the Electrode unit in place. The bead case should be filled up to approximately 6 mm above the notch of the bead case cover after putting the measurement electrode into the beads. See Figure 3.1.

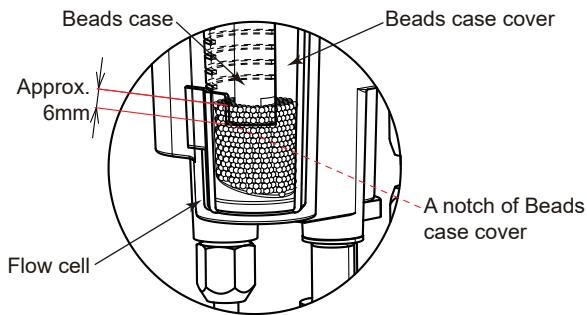

Figure 3.1 The amount of beads to be filled

3.5 Checking sand filter

This is an inspection to be performed when the specifications of the sampling device are -2□ or -3□. Make sure that the sand filter contains filter sand up to the position of the scale <10> on the filter tube.

If it is insufficient, open the lid on the top of the filter tube to replenish it.

For the filter sand, purchase a supplement or use a water supply filter sand with an effective diameter of 0.6 mm and an equality coefficient of 1.4.

3.6 Supplying samples

Supply the sample with a pressure of 50 to 100 kPa to the RC800D. Adjust the flow rate by the following procedure.

- (1) Supply the sample with the ball valve (*1) of the sample supply line on the back of the residual chlorine meter fully closed. For details on valve numbers, refer to “2.2 Piping”.

*1: For tap water (-1□): V1, for raw water measurement One Sand Filter (-2□): V3,
for raw water measurement DBL sand filters (-3□): V3, V4

- (2) Gradually open the ball valve for sample supply in item (1) and let the sample flow at the specified flow rate (*2).

*2: For tap water (-1□): 1 to 4 L/min, for raw water measurement One Sand Filter (-2□): 5 to 10 L/min,
for raw water measurement DBL sand filters (-3□): 10 to 20 L/min (5 to 10 L/min per flow path)

Adjust the valve opening so that the sample flows out from the outlet on the side of the head tank or sand filter at a water level of about 1/4 of its diameter.

3.7 Supplying the cleaning water

This section applies when a code for the sampling system “-2□” or “-3□” is specified.

Supply cleaning water (tap water) with a pressure of 100-500 kPa to the residual chlorine analyzer.

Leave the ball valves V4 (-2□) and V6 (-3□) of the cleaning water line on the back of the residual chlorine analyzer fully open.

Make sure that the cleaning water does not leak from the solenoid valve when the ball valves [V1, V2 (-2 □)] and [V1, V2, V5 (-3 □)] of the filter sand cleaning line and the glass bead cleaning line at the bottom of the sand filter are in the “closed” state. Then completely close those valves.

3.8 Polishing measurement electrode

Before measurement, polish the measurement electrode. For the polishing procedure, refer to “8.1 Replenishment of reagent” .

3.9 Supplying power and switching to maintenance mode

Make sure the power supply has a voltage and frequency that meets the specifications of the residual chlorine meter.

Also make sure the smart unit, relay box, and FLXA402T fuse are installed correctly. (see “8.8 Liquid flow pump delivery rate confirmation and adjustment”).

The residual chlorine analyzer does not have a power switch. When the switch provided on the power line is turned on, the residual chlorine analyzer works.

Note: If you specify the specification “/ARS (with arrester)”, a power switch (circuit breaker) is installed in the arrester box.

Before supplying power, confirm that the water supplying and wiring are correctly installed.

Once the power is supplied, the Chlorine sensor unit starts in a measurement mode and the measurement electrode starts rotating.

Turn the Maintenance mode ON until the operation preparation is completed. To go to the Maintenance mode, switch on the  MAINT on the Main display.

3.10 Checking pump delivery rate

The liquid flow pump is factory adjusted to the specified flow rate.

Check this flow rate as follows.

From the FLXA402T main screen > Sensor menu > Maintenance menu > Liq. pump flow rate

Work on the Liq. pump flow rate screen.

For details on Liq. pump flow rate screen refer to “5.6 Maintenance menu”

If the flow rate is appropriate without adjusting the pump, the recording of the Adj. finished date is not necessary.

3.10.1 Checking a sample flow rate

Prepare a 200 mL graduated cylinder. The delivery rate of sample is measured by measuring the time during which a fixed amount (150 mL) of the sample is poured into the measuring cylinder from the drain cock at the bottom of the measuring tank.

- (1) Check that 150 mL is entered in the box of Sample capacity at the bottom of the Liq. pump flow rate screen.
- (2) Loosen the drain cock. After draining the liquid accumulated in the measuring tank, the sample flowing out of the drain cock is received in the measuring cylinder.
- (3) Tap the [Start / Stop] button when the sample is poured to the reference scale of the graduated cylinder. Counting starts.
- (4) When the sample in the graduated cylinder increases by 150 mL from the reference scale, tap [Start / Stop] again. The flow rate display shows the flow rate calculated from the capacity and the measured time.

If the flow rate is 50 ± 5 mL / min, the delivery rate of the sample flow pump is normal.

If the delivery rate is not appropriate, adjust the position of the stopper on the drive of the liquid flow pump. (see “8.8 Liquid flow pump delivery rate confirmation and adjustment”).

- (5) Close the drain cock. Then check the delivery rate of the reagent flow pump.

3.10.2 Checking reagent quantity

Prepare a 50 mL burette and a $\phi 6 \times \phi 4$ mm soft PVC resin tube with a length of about 120 cm to be used for the check. It would be easier to work if you also prepare a burette stand.

See Figure 3.2 for how to set the burette.

The delivery rate is measured by measuring the time that a certain amount (4.5 mL) of water in the burette is consumed.

- (1) On the liquid pump flow rate adjustment screen, check that the measurement volume on the reagent side in the top row is 4.5 mL.
- (2) Tap the [Pump On / Off Button] to stop the operation of the liquid flow pump.
- (3) Close the ball valve (* 1) on the reagent distribution line. Then, remove the pipe connected to the pipe joint on the suction side of the reagent flow pump.

*1: For tap water -1□: V3, for One sand filter -2□: V6, for DBL sand filter -3□: V8

- (4) Connect the prepared soft PVC resin tube to the burette and fill the tube and burette with water (reagent substitute). Then, connect the other end of the tube to the piping joint on the suction side of the reagent liquid flow pump, and set the burette as shown in Fig. 3.2. Consumption is measured within ± 10 cm of the top of the detector as standard, as shown in Figure 3.2.
- (5) Restart the operation of the flow pump.
- (6) The screen returns to the liquid pump flow rate adjustment screen. Tap the [Start / Stop] button when the liquid level in the burette drops to the reference scale (optionally defined) within the limit range. The count will start.
 - The water in the burette will decrease at a constant rate, so tap the [Start / Stop] button when the water level falls 4.5 mg below the reference scale.
 - The counted number of seconds is calculated as the consumption rate of 4.5 mL and the flow rate is displayed. If the flow rate is 1.5 ± 0.15 mL / min, the reagent liquid flow pump delivery rate is normal. If the delivery rate is not appropriate, adjust the position of the stopper on the drive of the liquid flow pump. (see “8.8 Liquid flow pump delivery rate confirmation and adjustment”).
- (7) Tap the [Pump On / Off] to stop the liquid flow pump. Remove the tube connected to the piping joint on the suction side of the reagent liquid flow pump, and replace the piping.
- (8) Open the ball valve on the reagent distribution line. Operate the liquid flow pump.

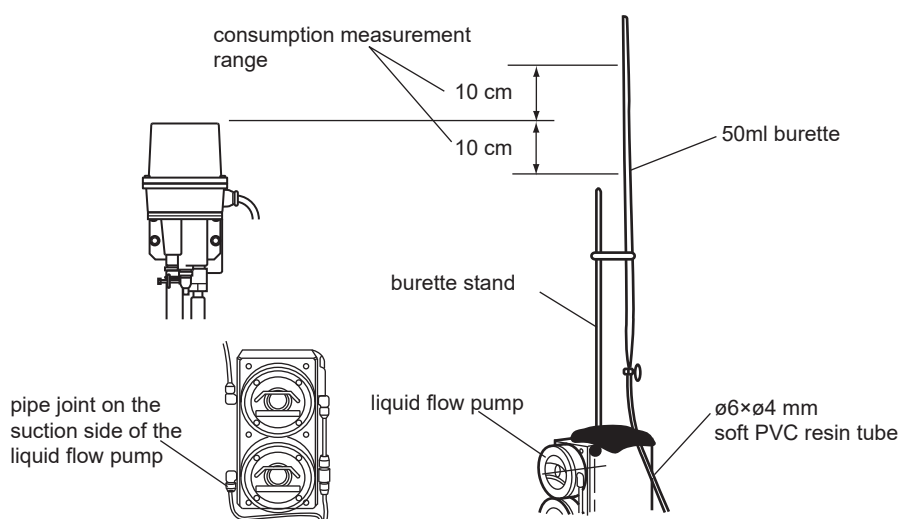

Figure 3.2 Setting burette

3.11 Verifying operation of the Measurement electrode

Check that the Measurement electrode rotates normally in the sample and beads are smoothly moving. Screw and fasten the Electrode unit if no problem exists.

3.12 Checking the solenoid valve for cleaning and the opening of the ball valve

Check the operation of the cleaning solenoid valve and the opening of the ball valve only when the sampling system in the specification is a residual chlorine analyzer of -2□ or -3□.

Check the operation of the solenoid valve and adjust the opening of the ball valve as follows. Be sure to carry it out in maintenance mode.

- (1) Adjust the flow rate of cleaning water entering the sand filter.
 - Manually turn the solenoid valve SV4 to On (valve: open).
 - Adjust the opening of the ball valve V1 at the bottom of the sand filter. Control the valve opening so that the filtration in the sand filter does not rise above the sample inlet.
 - After adjusting the opening of the ball valve, turn off the solenoid valve SV4. When you use a residual chlorine analyzer with the DBL sand filters (-3□), adjust the flow rate of the cleaning water that enters the other sand filter.
 - Turn on the solenoid valve SV5 (valve: open). Control the ball valve V5 so that the filtration in the sand filter does not rise above the sample inlet.
- (2) Adjust the flow rate of cleaning water entering the flow cell.
 - Manually turn the solenoid valve SV2 to On (valve: open).
 - Then gradually open the ball valve V2 to adjust the flow rate. Adjust it so that the glass beads in the flow cell are lifted and the liquid level does not exceed the second slit from the top of the bead case.
 - After adjusting the flow rate of the cleaning water, stop the operation of the solenoid valves SV2, SV4, SV5.

3.13 Supplying purging air

Halogen gas is highly corrosive. Provide air purge the inside of the container such as the electrode unit so that the metal part does not corrode due to the intrusion of halogen gas generated from the sample. If an air pump is attached, turn on the air pump on the manual operation screen.

CAUTION

The air to be purged should be clean air.

When using instrumentation air, etc., reduce the pressure to 140 kPa before supplying. Keep the electrode unit and the liquid flow pump lid that are air purged tightly closed.

3.14 Filling zero water and Test operation (for auto zero calibration)

For auto zero calibration to proceed smoothly, feed zero water (chlorine-free water) through the zero filter case in advance.

After replacing the filter, or when the automatic calibration function is disabled for a long time, the zero water has to keep flowing for a while in maintenance mode to stabilize zero filter.

- Make sure SV2 is closed and open SV3. (RC800D for water purification and distribution does not have SV2.)
- Confirm that water does not leak from activated charcoal filter or piping, or there is no bubbles in the pipeline.
- Let it run for about 20 minutes and check that the indicated value of the residual chlorine meter is near zero.

After the test operation is completed, set the calibration cycle, calibration preparation time, and calibration recovery time suitable for the sample and measurement environment.

- Confirm that water does not leak from activated charcoal filter or piping, or there is no bubbles in the pipeline.
- Supply tap water to activated charcoal filter. Filtrated water is zero water and supply it to the flow cell. Turn on SV3 on the manual operation screen. When -2A or -3A is specified for the sampling system, check that SV2 is Off.
- Keep feeding zero water over 20 minutes and confirm measurement value is stable around 0 mg/L.
- Stop the zero water and supply sample to the flow cell. Turn off SV3 on the manual operation screen.

3.15 Setting Operation Parameters

The RC800D is preset with defaults at the time of factory shipment.

Before measurement, verify that these factory default settings meet your operating conditions and if necessary, reconfigure parameters.

When user changes the operation parameter, note down the changed data.

Set the appropriate parameters to suit your operating conditions.

- 1: Configure Display and Output setting parameters on the converter.
Refer to IM 12A01G01-03EN FLXA402T Operation of Converter.
- 2: Configure Sensor parameter for Chlorine sensor unit. Refer to “4. Setting parameters”.
- 3: Configure Auto wash/cal setting parameters.
Set parameters for sequence operation on the converter. Refer to “4.5 Auto Wash/ Calibration setting”.

3.16 Calibration

Warm up the RC800D for about an hour under normal operating conditions before calibration.

(Note) The electrode characteristics are not stable immediately after polishing the electrode. Leave the instrument running for a while before calibration.

Refer to “7. CALIBRATION” for calibration requirements.

3.17 Switching to measurement mode

When it is ready to operate, switch off the maintenance mode to shift to the measurement mode. Make sure no error message appears.

4. Setting parameters

This chapter describes how to set the parameters specific to the residual chlorine meter.

The description contains the “Automatic Cleaning / Calibration Settings” parameter, which can be set from the detector menu or the converter menu.

For other settings in the converter menu, refer to FLXA402T Operation of Converter IM 12A01G01-03EN operating section of the FLXA402T screen / converter menu.

For details on how to switch to the sensor setting screen, read FLXA402T Operation of Converter IM 12A01G01-03EN.

About other parameter setting of the converter menu, read FLXA402T Operation of Converter IM 12A01G01-03EN.

Table 4.1 Sensor setting

Menu	Parameter	Default	Reference	
Measure setting	Negative value non output	Disable	4.1.1 Negative value non output	
	Chlorine unit select	mg/L	4.1.2 Chlorine unit/Temperature unit	
	User-defined unit			
	Temperature unit	°C		
	Meas. damping time constant	10.0 sec	4.1.3 Meas./Maint. damping time constant	
	Applied voltage (fixed or start)	-0.4V or +0.6V (*3)	4.1.4 Applied-voltage Compensation	
	Applied voltage compensation	Disable		
	Applied voltage comp. slope	-0.02 V/μA (*4)		
	Chlorine warning High limit	11(*1)	4.1.5 Chlorine warning High/Low limit	
	Chlorine warning Low limit	-1(*1)		
	Electrode rotating speed	600 rpm	4.1.6 Electrode rotating speed	
Compensation setting	Temp. input for compensation	Pt1000	4.1.7 Compensation setting	
	pH compensation	Disable		
Cal./Maint. settings	Maint. damping time constant	6 s	4.1.3 Meas./Maint. damping time constant	
	Stability check allowable width	0.010 mg/L (*1)	4.2.1 Stability check	
	Stability checking time	10 s		
	Stability check limit time	7 min		
	Temp. offset	0 (*2)	4.2.2 Temp. offset	
	Wash/Cal. box	Disable	4.2.3 Wash/Cal. box	
	Plateau data acquisition set	Start voltage	1.00 V	4.2.4 Plateau data acquisition set
		Voltage step interval	-0.20 V	
		Number of steps	10	
		Recovery time after plateau acq.	5.0 min	
Calibration setting others	Zero	0.00 μA	4.2.5 Calibration setting others	
	Slope	100.0%		
	Sens.factor	2.620 μA/ppm		
Diagnosis setting	Empty cell detection	Disable	4.3.1 Empty cell detection	
	Empty cell detection conc.	0.080 mg/L (*1)		
	Signal status	Enable	4.3.2 Signal status	
	ME operation days count	Enable	4.3.3 Operation days	
	Motor operation days	Enable		
	Beads operation days	Enable		
	Coupling operation days	Enable		
	Shaft assy operation. Days	Enable		
Communication setting	Sensor connection address	1	4.4 Communication setting	

*1 Depend on the unit of configured residual chlorine

*2 Depend on the unit of configured temperature

*3 When a code -F: Free chlorine in Measurement object or -T; Residual chlorine is specified, -0.4V, when -C; Combined chlorine insensitive version is specified, +0.6V is preset at factory shipment.

*4 Not available for RC800D.

After an initialization, set each value to default described in the user's manual.

Table 4.2 Converter setting

Menu	Parameter	Default	Reference
Auto wash/ cal. setting	Auto sequence for wash/cal.	Disable	4.5.1 Auto sequence for wash/cal.
	First start year YY	00 (year) *1	4.5.2 Start date
	First start month MM	1 [month]	
	First start date DD	1 [day]	
	First start hour hh	0 [h]	
	First start minute mm	0 [min]	
	Auto update of next start date	Off	
CL setting	Auto detector wash function	On	4.5.3 Wash/Calibration On/Off
	Auto sand filter wash function	On	
	Auto calibration function	Off	
	Washing interval	1 [hour]	4.5.2 Start date
	Calib. interval	7 [days]	
	Washing time for detector	1 [min]	4.5.4 Auto sequence for wash/cal.
	Washing time for sand filter	1 [min]	
	Recovery time after wash	5 [min]	
	Washing interval for DBL sand filt.	2 [hour]*2	
	Replacing time for DBL sand filt.	6 [min]	
	Cross time for DBL sand filter	1 [min]	
	Waiting time for calibration	10 [min]	
	Recovery time after calibration	10 [min]	

*1: Specify the last two digits of the year (YY).

*2: The cleaning cycle of DBL sand filter is set to 0.5 hours at the time of factory shipment. If the converter is initialized, it will be set to 2 hours, so change the set value if necessary.

4.1 Measure setting

4.1.1 Negative value non output

When the negative value non output is enabled and the measured value becomes negative, the measured value is displayed as 0, and the mA output also outputs the current value with the measured value of 0.

When the negative value non output is set to be disabled, both the display and the mA output become negative values.

4.1.2 Chlorine unit/Temperature unit

Select chlorine unit mg/L, ppm, or user defined unit. If you select a user defined unit, the unit is displayed in text. You cannot change temperature unit here. To change the temperature unit, go to Converter menu for setting.

4.1.3 Meas./Maint. damping time constant

Processing time constant provides the smooth control of fluctuation of chlorine concentration measurement. Set 63 % response time as an appropriate time constant.

The larger value the time constant has, the more stable the chlorine concentration value becomes but the slower the response becomes.

Meas. damping time constant is used in a measurement mode.

Maint. damping time constant is used in the following period:

- Maintenance mode
- Calibration
- Auto wash/calibration
- Plateau data acquisition

Maint. damping time constant is set smaller than Meas. damping time constant to make the response faster.

4.1.4 Applied-voltage Compensation

Select Disable for the applied voltage compensation function. With RC800D, the voltage guarantee does not work.

The applied voltage value is always the [Applied voltage (fixed or start)] value.

4.1.5 Chlorine warning High/Low limit

Set the High or Low limit of the chlorine value. If the value exceeds the upper or limit, a warning appears respectively.

4.1.6 Electrode rotating speed

The rotational speed of the electrode is fixed to 600 rpm and not changeable.

4.1.7 Compensation setting

For the temperature compensation input, select temperature obtained by a temperature sensor (PT1000) incorporated in a reference electrode, or use value input by external devices. PT1000 is generally used.

As an external temperature input, the temperature measured by the detector connected to the sensor Ch2-1 or the temperature value analog input from the external converter can be input to the sensor Ch1-1.

When using the analog input from an external converter, set the temperature AI input in the converter settings.

PH compensation is not available on the RC800D. Set it to disabled.

4.2 Calibration/Maintenance settings

4.2.1 Stability check

You can configure the following parameters to evaluate the measurement stability in a calibration and a plateau data acquisition.

- Stability check allowable width
- Stability checking time
- Stability check limit time

The measurement stability is verified, when the measurement stays within the range of "Stability check allowable width" without exceeding the range for longer than the set period of "Stability checking time".

If the measurement does not become stable before "Stability check limit time", a confirmation dialog appears to abort the calibration. During Plateau data acquisition, the process is skipped without recording a plot value.

When a sample of 3mg/L or more is used, set the Stability check value width to the value for 0.5 mg/L or above.

4.2.2 Temp. offset

Temp. offset can correct the temperature deviation when temperature is measured with temperature sensor PT1000.

(e.g. When the actual temperature turns out 1°C higher than the displayed temperature, set the value "1".)

4.2.3 Wash/Cal. box

Wash/Cal. box refers to a relay box mentioned in "2.3 Wiring". Set it to enable. If it is disabled, the flow pump or solenoid valve will not operate.

4.2.4 Plateau data acquisition set

To obtain the plateau characteristic, configure this setting. This setting also relates to display of plateau characteristic acquisition.

Decide condition and the number of data to obtain according to the initial applied voltage, the applied voltage width, or the step count. In general, set the applied voltage width to a negative value to make the value of the applied voltage change from positive to negative.

Figure 4.1 shows the relationship between the initial applied voltage, step applied voltage, and step count.

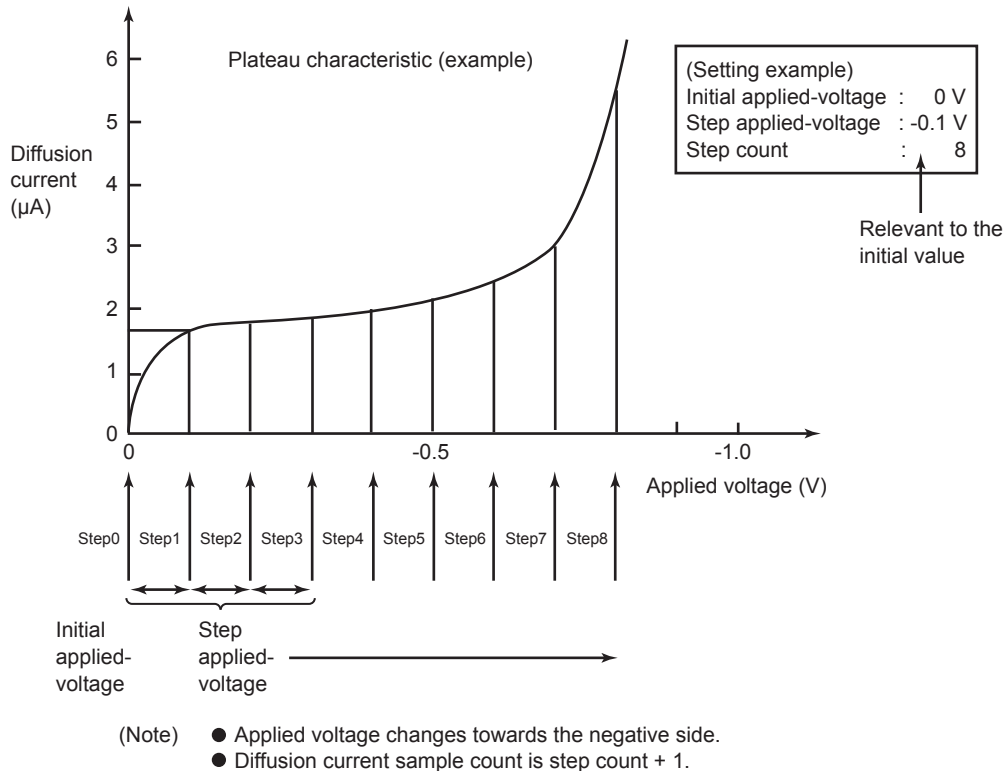

Figure 4.1 Example of Plateau Characteristic Collection

F6-2e.ai

4.2.5 Calibration setting others

Zero, Slope, Reference sensitivity can be input manually. However, Yokogawa recommend going to sensor "Detail" to refer to the setting.

Do not change those setting except for resetting value.

4.3 Diagnosis setting

4.3.1 Empty cell detection

Set Empty cell detection enable/disable. Yokogawa recommend that the detection initial concentration be set lower than 1/3 of the usual measurement value, considering the possibility of liquid shortage.

4.3.2 Signal status

Set Signal status display enable/disable. The status appears on the sensor "Detail". Set disable when the measurement value is lower than 0.3 mg /L.

4.3.3 Operation days

Set Operation days display about each item enable/disable.
If you want to confirm the value of operation days on sensor "Detail" screen, enable the function.
Even if you set it disable, the operating day counts internally.

4.4 Communication setting

■ Sensor connection address

You can change Sensor connection address of sensor to connect. After changing the address, you also need to change the sensor address on the converter that connects to the system. To change the converter setting,

go to Converter menu > Converter setting > Modbus address (S).

See 4.6.1 in FLXA402T Operation of Converter IM 12A01G01-03EN.

CAUTION

Changes in the sensor address settings are activated by turning off the power of the sensor and then on.

4.5 Auto Wash/Calibration setting

This section describes a converter setting.

4.5.1 Auto sequence for wash/cal.

Enable this function to use Auto wash/calibration. If this function is disabled, Auto wash/calibration is not performed even if other setting is active.

4.5.2 Start date

First enter a date/time to carry out Auto wash/calibration. Enter a future date/time for the first Start date. When the setting value is past time, Auto wash/cal is never started.

If you want to perform the next and subsequent Auto wash/calibration automatically, turn ON Auto update of start date. The next date of Auto wash/calibration is automatically set according to the wash/calibration set interval.

4.5.3 Wash/Calibration On/Off

Select On/Off on auto flow cell cleaning, auto sand filter cleaning, auto calibration respectively.

What is carried out in each of the cleaning cycle and the calibration cycle differs depending on the sampling device.

■ without sand filter (-1A)

When the automatic calibration function is turned on, automatic calibration is performed. Even if the automatic flow cell cleaning function is turned on, flow cell cleaning will not be performed.

■ One sand filter (-2N, -2A)

	Wash cycle	Calibration cycle
Flow cell cleaning: On, Calib. : On, Sand filter cleaning: On	Auto flow cell cleaning + Auto sand filter cleaning	Auto flow cell cleaning + Auto calibration
Flow cell cleaning: On, Calib. : Off, Sand filter cleaning: On	Auto flow cell cleaning + Auto sand filter cleaning	not performed
Flow cell cleaning: Off, Calib. : On, Sand filter cleaning: On	Only Auto sand filter cleaning	Only Auto calibration
Flow cell cleaning: Off, Calib. : Off, Sand filter cleaning: On	Only Auto sand filter cleaning	not performed
Flow cell cleaning: On, Calib. : On, Sand filter cleaning: On	Only flow cell cleaning	Auto flow cell cleaning + Auto calibration
Flow cell cleaning: On, Calib. : Off, Sand filter cleaning: Off	Only flow cell cleaning	not performed
Flow cell cleaning: Off, Calib. : On, Sand filter cleaning: Off	not performed	Only auto calibration
Flow cell cleaning: Off, Calib. : Off, Sand filter cleaning: Off	not performed	not performed

When -2N is specified, do not turn on the auto calibration function.

■ Double sand filter (-3N, -3A)

	Wash cycle	Calibration cycle
Flow cell cleaning: On, Calib. : On	Auto flow cell cleaning	Auto flow cell cleaning + Auto calibration
Flow cell cleaning: On, Calib. : Off	Auto flow cell cleaning	not performed
Flow cell cleaning: Off, Calib. : On,	not performed	Only Auto calibration
Flow cell cleaning: Off, Calib. : Off	not performed	not performed

If the DBL sand filter type is used and the automatic sand filter cleaning function is on, the sand filter cleaning sequence always operates separately from the above cases.

When -3N is selected, do not turn on the automatic calibration function.

4.5.4 Auto sequence for wash/cal.

Set the automatic cleaning cycle to set the automatic cleaning schedule, and set the automatic calibration cycle to set the automatic calibration schedule.

On the set "First start date and time" date, the automatic sequence operates every cycle set here.

If the timings of automatic cleaning and automatic calibration overlap, automatic calibration takes precedence. If the timing of the automatic calibration cycle comes in the middle of the operation in the automatic cleaning cycle, the automatic cleaning sequence is interrupted and the flow cell cleaning for automatic calibration starts.

For other setting items, make detailed settings for each operation in one automatic cleaning / automatic calibration.

See "Appendix Automatic wash/Automatic calibration Sequence".

■ Time Scheduling for Auto wash and Auto calibration

● When Auto detector wash function is on

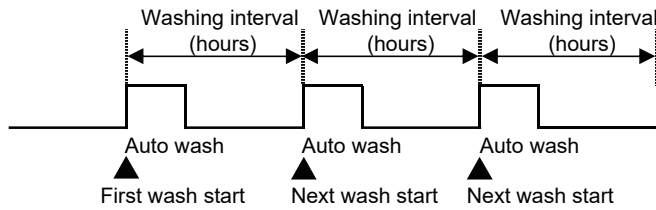

● When Auto calibration function is on

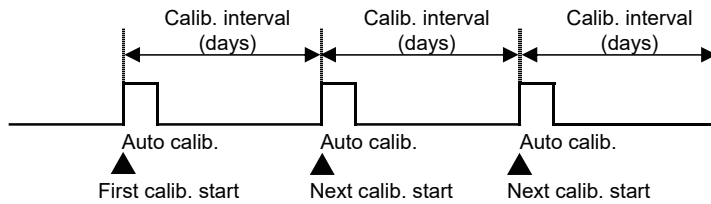

● When Auto calibration function is on and calibration cycle is 10 days or more (setup Auto detector wash function to disable.)

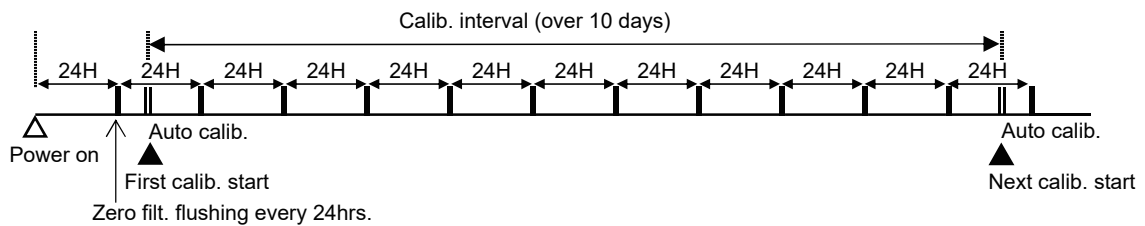

When auto calibration and zero-filter flushing overlap, auto calibration takes precedence.

● Zero-filter flushing when Auto calibration function is used

This function prevents the activated charcoal filter from being decayed.

The zero-filter flushing function operates automatically once every 24 hours when the following conditions are satisfied in the automatic wash and automatic calibration setup of converter setting.

- Auto wash calibration function is enabled
- Auto calibration function is enabled
- Auto-zero calibration period longer than 1 day

When the zero-filter flushing operation is activated, zero-water is passed for the time setup in Waiting time for calibration, and then the sample water is passed for the time setup in Recovery time after calibration. During this time, operation mode is the auto wash status and the reading is corresponding with the auto hold setting.

24-hour counting begins after Power Supply is on. This function is active when all of the above conditions are satisfied under the measurement mode. (Auto wash is interrupted.)

5. FLXA402T sensor menu

The FLXA402T sensor menu can be operated from the icon below.

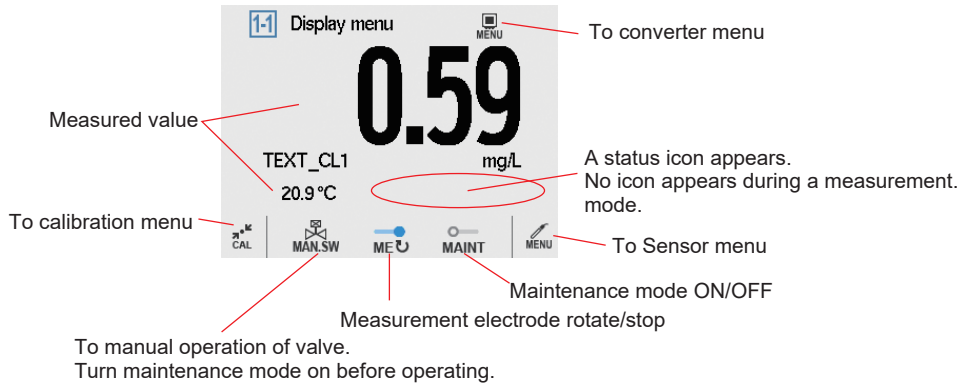





Figure 5.1 Main screen example

Shortcuts on Main screen go to the following menu directly.

-  to Valve operation
-  to Rotation of measurement electrode dialog
-  to Maintenance mode dialog

For details see “5.6 Maintenance menu”.

To go to Sensor menu,

Start up> Main screen  > Sensor menu

The following operation are available.

- Auto wash (start auto washing)
- Calibration (sensor calibration)
- Setting (sensor setting)
- Sensor maintenance
- etc.

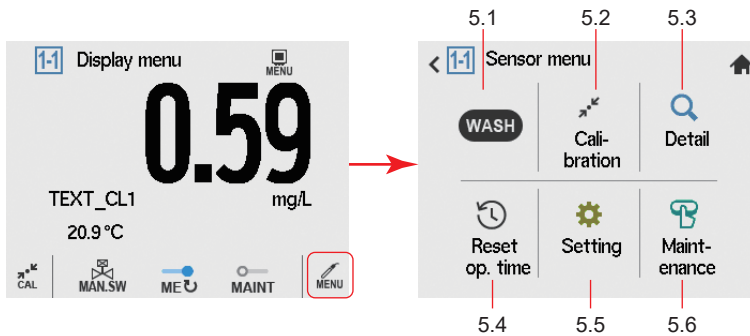

Figure 5.2 Sensor menu

5.1 WASH

On Sensor menu, tap **WASH** “WASH” > a dialog to start manually

Tap “Start” then Auto Wash.runs only one time.

While the wash is in progress, **WASH** appears.

To stop the wash, tap **WASH**. When the wash stops or is cancelled, the screen shifts to a recovery mode and **WASH** starts flashing. During the recovery time, tap **WASH** to cancel the recovery and return to a measurement mode.

NOTE

During a maintenance mode, no wash can start.

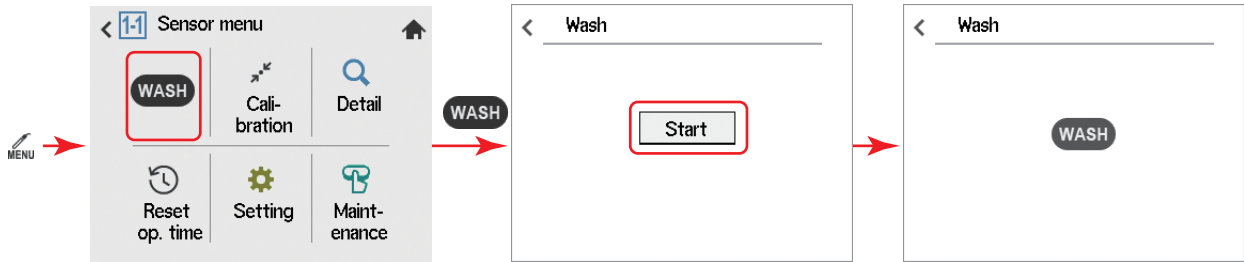

When you have a password, a password verification dialog appears. Upon successful confirmation, Wash screen appears.

For further information on the password setting, see FLXA402T Operation of Converter IM 12A01G01-03EN 5.4 Password.

5.2 Calibration

On Sensor menu, tap **Calibration** “Calibration” > Calibration menu

Or on Main Screen, tap **CAL** > Calibration menu

For further information about Calibration, see Chapter 4.

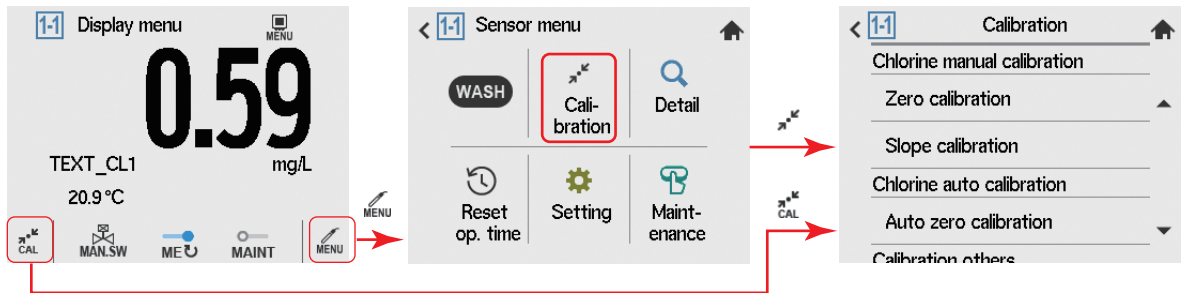

When you have a password, a password verification appears. Upon successful confirmation, Calibration screen appears.

For further information on the password setting, see FLXA402T Operation of Converter IM 12A01G01-03EN 5.4 Password.

5.3 Detail

On Sensor menu, tap  "Detail". The next figure shows the screen flow. You can view the detail information on settings, sensor wellness, calibration, the product information including the serial number etc.

If you are in trouble and contact Yokogawa service, please inform us of the serial number and software revision displayed on the Detail screen in addition to the production number indicated on the nameplate attached to the instrument.

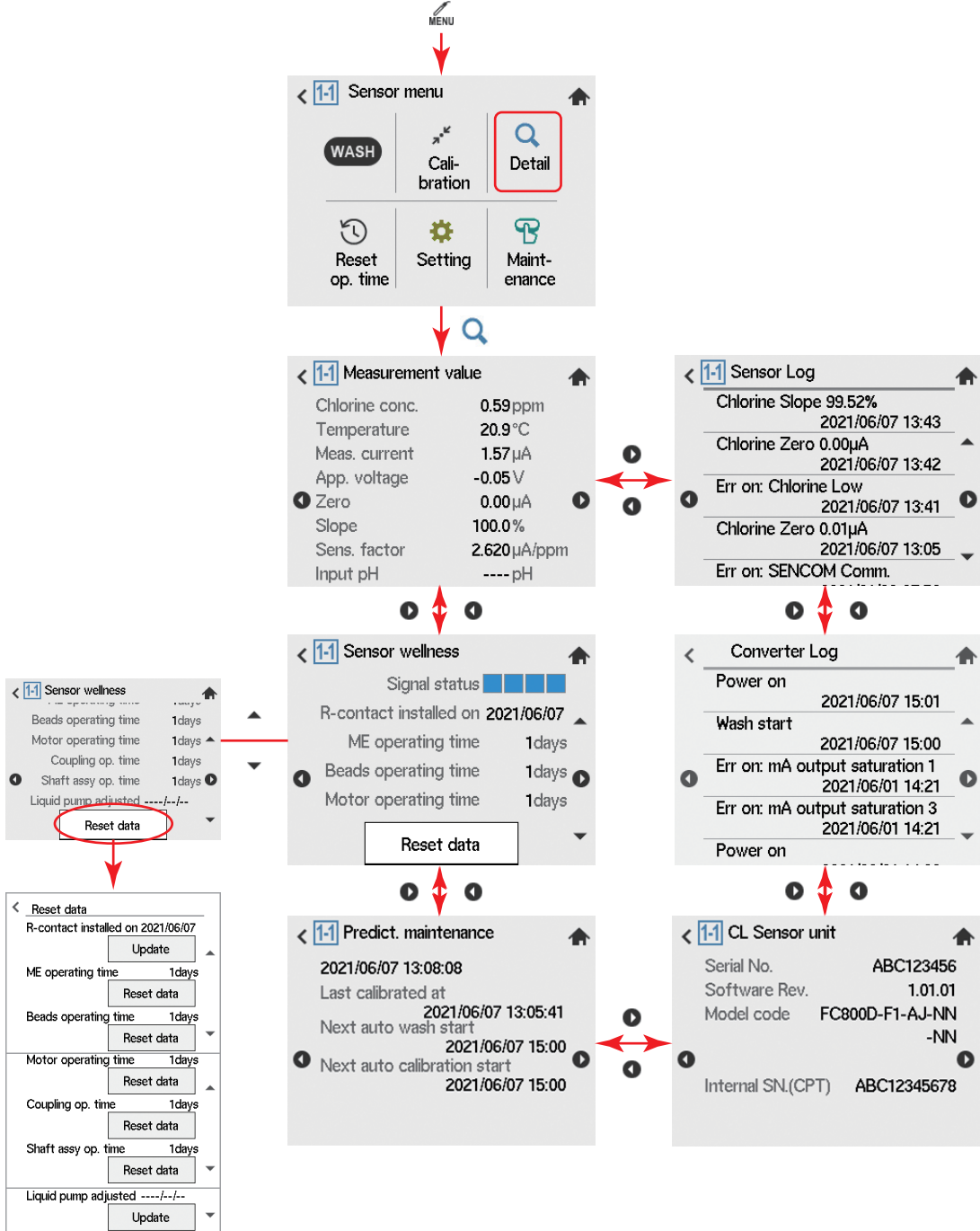

Figure 5.3 Sensor menu flow chart

■ Measurement value

- **Chlorine conc., Temperature**

Shows the residual chlorine concentration and temperature displayed on Main screen.

- **Meas. current, App. voltage**

Shows the diffusion current and applied voltage.

- **Zero, Slope, Sens. factor**

We recommend that you make a note of the each value of these items before calibration, because the calibration may overwrite those values.

- **Input pH**

Shows Input pH value, which is input from Converter for pH compensation. The value is displayed only when pH compensation is enabled.

■ Sensor wellness

- **Signal status**

Shows stability of Diffusion current signal. The number of ■ represents the status: the more ■ appears in each gauge, the less fluctuation the signal makes. Noise or other disturbance or large change in chlorine concentration reduces the number of ■. A gauge is displayed only when the setting of Signal status is enabled. If the setting is disabled, a bar (----) is displayed.

- **R-contact installed on, ME operating time, Beads operating time, Motor operating time, Coupling op. time, Shaft assy op. time**

Manages installation date of Rotating contact and manages the number of operating days of measurement electrode, beads, motor, driven shaft assembly.

To reset each data, go to dialog of Sensor wellness reset. Press reset, then the number of operating days is reset to 0 but only the sensor installation date is updated. See 5.4.

Only when the wellness setting is enabled, the result is displayed.

- **Liquid pump adjusted**

Shows the date of adjustment of the liquid flow pump. See 5.6.5.

■ Predict. maintenance

- **Last calibrated at**

Displays a date when the last auto calibration took place and the last calibration menu was implemented.

- **Next auto wash start, Next auto calibration start**

When Next auto wash start or Next auto calibration start is scheduled, those dates are displayed. If you set a date/time for the first time operation, the date and time for the first time operation is displayed. When you set Next auto wash/calibration date to be updated automatically, these dates are automatically updated.

■ CL Sensor unit

Displays Serial number (Serial No.) of a connected Chlorine sensor unit, software version (Software Rev.), Model code (Model code), internal serial number (Internal SN. (CPT))

■ Converter log, Sensor log

Same display as on the converter "Detail".

See 3.1 in FLXA402T Operation of Converter IM 12A01G01-03EN.

5.4 Reset op. time

To reset wellness data of each sensor

Sensor menu > ⌚ Reset op. time > Sensor wellness , tap “Reset data”.

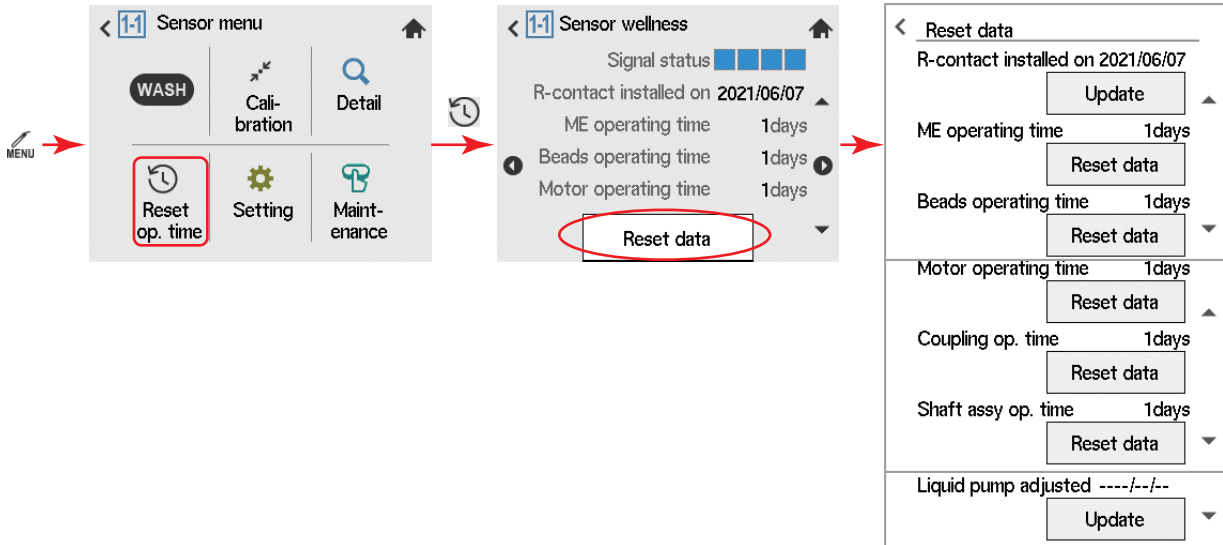

You can reset each data on the Reset data dialog. When you reset the data, the numbers of operating days are reset to 0 and the date of R-contact installed on/Liquid pump adjusted is updated to the date when the reset is implemented.

When you have a password, the password verification appears. Upon successful confirmation, Reset confirmation dialog appears.

For further information on the password setting, see FLXA402T Operation of Converter IM 12A01G01-03EN 5.4 Password.

5.5 Sensor setting menu

Sensor menu > ⚙ Setting > Sensor setting menu

You can configure and initialize sensor parameters.

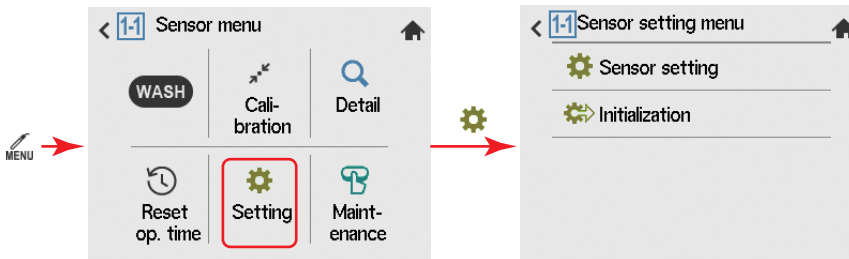

When you have a password, the password verification dialog appears. Upon successful confirmation, Sensor Setting screen appears.

For further information on the password setting, see FLXA402T Operation of Converter IM 12A01G01-03EN 5.4 Password.

If you go to Sensor setting, the Maintenance contact is turned ON, and other contact output keeps the current status. When automate hold function is enabled, mA output is held.

■ Sensor setting

Configure sensor parameters. See “4. Setting parameters” for further information.

■ Initialization

Initialize sensor parameters.

If you tap “Execute”, the loading starts. When the loading ends, the screen will return to Sensor menu.

Confirm the items to reset before tapping Execute. Initialization/reset includes basic (reference) sensitivity value which is calibrated before shipping. Initialization makes all values common default.

5.6 Maintenance menu

Sensor menu > Maintenance > Maintenance menu

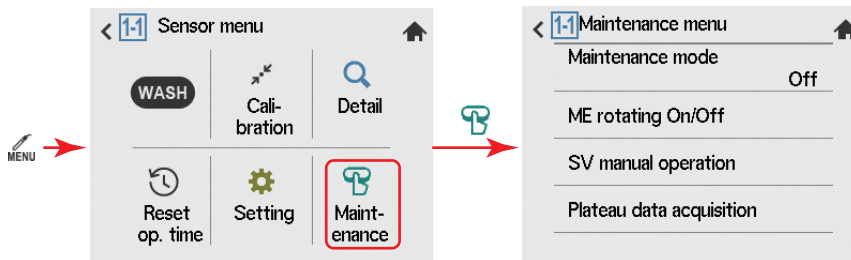

When you have a password, the password verification dialog appears. Upon successful confirmation, Maintenance menu appears.

For further information on the password setting, see FLXA402T Operation of Converter IM 12A01G01-03EN 5.4 Password.

5.6.1 Maintenance mode

Switches the mode between the measurement and the maintenance. You can also switch by tapping on Maintenance icon on Main screen. For Maintenance mode, see “3. Preparation for OPERATION”.

5.6.2 ME rotating On/Off

Switches On/Off the rotating of measurement electrode. You can also switch by tapping ME icon on Main screen.

5.6.3 SV manual operation

Can manually control Solenoid valves of valve operation for Auto Wash/Calibration.

First you need to switch to measurement mode. Tapping MAN.SW icon on Main screen also leads you to the same screen.

5.6.4 Plateau data acquisition

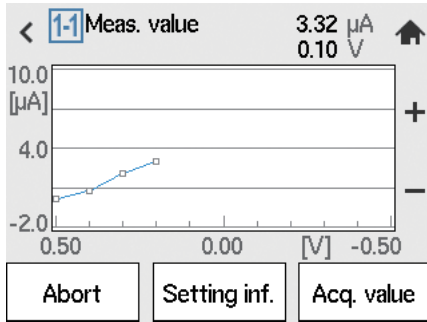

Figure 5.4 Plateau data acquisition in progress

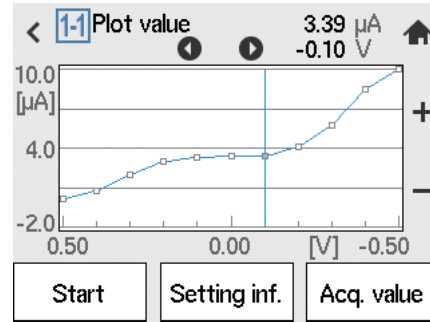

Figure 5.5 End of the data acquisition

Plateau data acquisition automatically acquires characteristics of sample voltage/current and plots the data on the graph.

A plateau region is flat with little current change by change of applied voltage. To change the applied voltage for chlorine measurement, set the applied voltage in this area.

Horizontal scale and number of plots vary according to the setting of Plateau data acquisition. Leave setup as it was when you acquired it.

Tapping [Setting inf.] will check the parameters used to obtain the plateau characteristic. When changing the setup, change setup parameter in the sensor setting menu. For details on the parameters, see section 4.2.4, “Plateau data acquisition set”.

Tap [Start] to begin acquiring the plateau data. Up to 21 values, depending on setup are recorded about the diffusion current at the applied voltage.

While the plateau data is being acquired, RC800D enters maintenance status.

If Auto hold is set to off, the mA output changes greatly due to a change in the applied voltage.

The data acquisition status stops when the acquisition is completed or when it is interrupted by the [Abort] button.



Immediately after the stopping, the recovery time starts.

Although the applied voltage is in the measurement value, mA output is in the same condition as when the plateau data is acquired in the recovery time.

The recovery time continues for the duration of a “setup Recovery time after plateau acq.”.

After the setup of Recovery time after plateau acq., the analyzer will automatically return to a measuring mode.

If you return to the main screen by tapping the  during the data acquisition, the process will also be aborted.

 Is blinking in the recovery time. If you want to return to the measurement mode immediately, tap  to abort the recovery time after confirming that the value of the residual chlorine is stable.

Tap [Acq. value] to display diffusion current and voltage values you have already obtained.

The number of displayed item varies according to the number of steps of the Plateau data acquisition set. Leave setup as it was when you acquired it.

The recorded plateau characteristic stay on until the power supply turns OFF or the next data acquisition is started. While the data stays on, you can review the result from Plateau data acquisition any number of times.

If the setting of Plateau data acquisition differs from when the plateau characteristic is obtained, the graph might not be scaled properly. If you turn off the power supply of the sensor, the acquired data is deleted.

5.6.5 Pump flow rate measuring

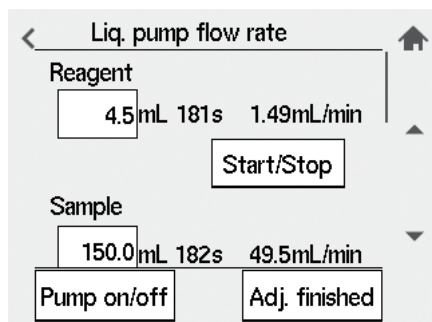

You can measure the pump flow rate.

Before measuring the flow rate, enter the volume of the liquid used to measure the reagent flow rate/sample flow rate.

Tap Start / Stop of the liquid (reagent or water to be measured) to be measured when starting the flow rate measurement.

Tap Start / Stop to reset the number of seconds and start counting from 0s.

At the same time, the flow rate calculated from the volume of the liquid and the number of seconds is displayed.

Tap Start / Stop again to stop counting seconds.

If the measured flow rate is within the default range, tap "Adj. finished".

Tap "Adj. finished" to record the pump flow rate adjustment date and time.

Tap Pump On / Off to move to the valve operation screen.

CAUTION

Pump flow rate is not saved. The pump flow rate is reset when you exit the pump flow rate measurement screen.

6. OPERATION

The following function works during normal operation of the RC800D.

6.1 Measurement of Residual chlorine

When Power Supply is turned ON, the residual chlorine sensor is activated in the measurement mode. The residual chlorine concentration is continuously measured.

Regular maintenance enables stable measurements. Refer to “8. MAINTENANCE” and “9. TROUBLESHOOTING”.

6.2 Empty cell detection

When Empty cell detection is set to enable, and the measured value falls below the Empty cell detection conc., the liquid empty detection is activated. During this time, converter's main screen displays **CHECK** **HOLD** and the measured value will be held.

When the flow cell is detected empty, the liquid empty detection alarm is activated and the rotation of the measurement electrode stops.

If the liquid empty is not detected, Hold is terminated after about two minutes and the measuring operation is restarted.

If the cell concentration remains lower than the level of Empty cell detection conc., the liquid empty detection function is activated every 10 minutes after the measurement restarts.

When the measurement electrode stops due to the liquid empty, the electrode re-starts rotating at the following timing.

- When the Empty cell detection alarm disappears (water returns to the flow cell)
- When maintenance mode is turned On

6.3 Automatic wash/Automatic calibration Operation

If the automatic wash/automatic calibration setup of converter's setting is performed properly, the automatic wash and automatic calibration operate at the scheduled time during measurement mode. Zero filter flashing may start depending on your setting. For details see the time schedule in “4.5.4 Auto sequence for wash/cal.”

You can see when the next automatic wash or automatic calibration starts from sensor detailed screen. The Auto wash/Auto calibration will not operate if a date of next auto wash/calibration is overdue.

Refer to FLXA402T Operation of Converter IM 12A01G01-03EN to know how the converter or mA output display look when Auto wash/Auto calibration runs.

When Auto wash /Auto calibration is being conducted, you cannot turn on Maintenance mode. You cannot enter Calibration menu or Setting menu, either.

6.4 Stop and restarting operation

To stop the operation, stop supplying power. When restarting operation, perform necessary inspection and maintenance referring to the chapter “8. MAINTENANCE”.

7. CALIBRATION

The calibration menu is described as below. Periodical calibration and an optimization of calibration parameters for Zero or Slope ensure accurate measurement. Perform calibration when the electrodes or the flow cells are free from contamination and the measured values are stable.

When you enter each calibration menu, sensor becomes calibration status. When you exit or cancel the calibration, **CAL** blinks on Main screen and sensor becomes calibration recovery state. mA output hold is kept during recovery time if Auto hold setting is enable. After confirming that the measured value becomes stable, return to the measurement mode. To return to a measurement mode, turn off the maintenance mode. You can also exit only the calibration recovery state by tapping **CAL**.

You also may need to operate the valve to switch between sample and standard solution to measure the calibration solution. The valve numbers to switch sample/standard solution are as follows.

For tap water measurement -1□:	V2
For One Sand Filter -2□:	V5
For DBL sand filters -3□:	V7

● Chlorine manual calibration

- Zero calibration “7.1 Zero Calibration”
Adjust the reading to zero point. Update the Zero of calibration parameter.
- Slope calibration
Adjust the reading to arbitrary concentration value. Update the Slope of calibration parameter.
Be sure to do this after Zero calibration.

● Chlorine Auto Calibration

- Auto zero calibration “7.3 Auto zero calibration”
Zero calibration is performed after Zero water is automatically fed and the cleaning is performed. This function is enabled only when the setting of Auto Wash/Auto Calibration is correct and the sampling system runs normally. Starting of auto calibration from this menu does not affect the auto start schedule (sequence) based on the setup cycle.

● Calibration others

- 2 Points calibration
Update the calibration parameters for Zero and Slope by using samples of two different concentration except for zero concentration.
- Basic (reference) sensitivity calibration “7.5 Basic (reference) sensitivity calibration”
Update the Sens. factor which is an important parameter for concentration calculation.
- Zero Cal. with circuit open “7.6 Zero calibration with circuit open”
Zero calibration while keeping samples or the electrode unit in a measurement position.
Update the Zero of calibration parameter.

7.1 Zero Calibration

The method of calibrating the zero point of the residual chlorine analyzer includes two approaches; open input circuit and chlorine-free-water-based measurement methods.

In the former method, the electrode is exposed in the air so that no current flows between the measurement electrode and reference electrode. The latter uses chlorine-free water or zero water (e.g. water filtered through activated charcoal).

The RC800D generally conducts calibration using the open input circuit method, which is more simple type of method. However, when you measure chlorine concentration lower than 0.1 mg/L or use combined chlorine insensitive version, use the chlorine-free-water-based measuring method.

[How to perform Zero calibration]

- 1 Turn on the maintenance mode.
- 2 Go to Zero calibration.
 - Open-input-circuit method
In the maintenance position of the electrode unit, expose the electrode in the air. Loosen the screws fixing the electrode unit. Lift the electrode unit out of the flow cell and leave it in the maintenance position.

- Chlorine-free-water-based measurement method
 - (1) Use about 2 to 3 liters of Zero water, which is made by passing the sample through an activated carbon filter. Put the solution in a proper container. Also, prepare a tube ($\phi 6 \times \phi 4$ mm) to supply this Zero water to the residual chlorine meter.
 - (2) Set the container containing the Zero water so that the liquid surface does not exceed the limit shown in Figure 7.1.
 - (3) Connect a tube for Zero water supply to the standard solution piping connection port (Rc 1/4 female screw) of the residual chlorine meter. Place the other end of the tube in the Zero water.
 - (4) Switch the valve of the sample-standard solution to "standard solution". Feed the Zero water to the sensor. The measured value usually stabilizes in about 5 to 10 minutes.
- 3 Press CAL on Main screen and go to the calibration menu.
- 4 On the calibration menu, select [Zero calibration] of Chlorine manual calibration.
- 5 Confirm the reading is stable. Tap [check stability] for checking the stability.
- 6 When a message pops saying that the reading is now stable, confirm the value is Zero. Press [Next].
- 7 Check the calibration result. Press [Accept] to update the parameter for Zero.
- 8 Turn off the maintenance mode to end the calibration.

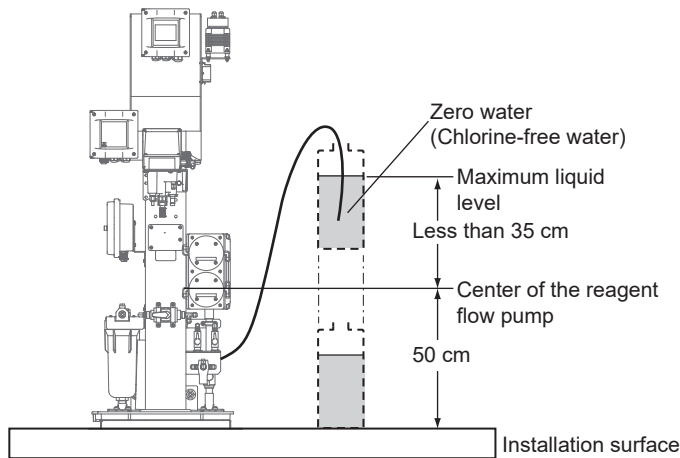

Figure 7.1 Zero water surface level

7.2 Slope calibration

When you calibrate both zero point and slope, first calibrate the zero point and then the span.

There are two slope calibration methods. One is a method in which the reading of the RC800D is adjusted to the value obtained by manual analysis. The other one is a standard solution method in which the reading is adjusted to the concentration value of calibration standard solution.

The former method is more common in general. However, the latter one is used when near-zero lower level concentration of residual chlorines constantly measured, which requires higher accuracy.

Set the calibration solution as shown in Figure 7.1. Insert the tip of the tube, which has been connected to the standard solution piping connection port during zero calibration, into the standard solution for calibration.

- **Using actual samples**

Samples in regular operation are used as calibration solution. Analyze the sample by laboratory analyzer or portable chlorine meter and use the result as calibration value.

- **Using standard solution**

Adjust the standard solution for calibration. The value of the adjusted standard solution obtained by laboratory analyzer is used for calibration.

Set the calibration solution as shown in Figure 7.1. Insert the tip of the tube, which has been connected to the standard solution piping connection port during zero calibration, into the standard solution for calibration.

(How to prepare a standard solution)

Dilute a commercially available sodium hypochlorite solution with pure water or tap water to make 2 to 3 L standard solution. Prepare a liquid near 80% of the measurement range during operation. Accurate concentration is checked by laboratory analyzer.

(How to do span calibration)

- 1 Turn ON the maintenance mode.
- 2 Feed calibration solution into the flow cell with reagent by the liquid flow pump. Verify that the electrode unit is ready for the measurement. Use the value for calibration obtained by manual analysis.
- 3 Press CAL on Main screen to enter the calibration menu.
- 4 Select Slope calibration on the calibration menu.
- 5 Confirm the reading is stable. Press [check stability].
- 6 When the message pops saying the reading is now stable, enter the calibration value and press [next]. Use the result of manual analysis from the second procedure mentioned above.
- 7 Check the calibration result. Press [Accept] to update the parameter for Slope.
- 8 Turn off the maintenance mode to end the calibration.

7.3 Auto zero calibration

Auto wash and auto zero run one time. Execute this operation in a measurement mode. You cannot have this calibration in a maintenance mode. This operation does not affect any automatic sequence schedule. Refer to "4.5.4 Auto sequence for wash/cal." for detail information.

7.4 2 points correction

The Zero point and slope are adjusted. Use two arbitrary known chlorine solution. Take two measurements and record the low concentration as "Low point", the high concentration as "High point". Be sure to take low point first, then do the measurement of the high point. Verify the result manually. The result of each concentration measurement are used as calibration value.

[How to perform a two point calibration]

- 1 Turn on the maintenance mode.
- 2 Feed the solution of "Low point" into the flow cell with reagent by the liquid flow pump.
- 3 Press CAL on Main screen to go to the calibration.
- 4 Select [2point calibration] in the menu list of Calibration others.
- 5 Confirm the reading stable. Press [check stability]
- 6 When a message pops saying that the reading is now stable, enter the calibration value. Press [Next].
- 7 Feed the solution of "High point" into the flow cell with reagent by the liquid flow pump. Wait until the reading becomes stable. After it becomes stable, press [Check stability].
- 8 When a message pops saying the reading is now stable, enter the result calibration value. Press [Next]
- 9 Confirm the result of calibration. Press [Accept] to update the parameter for Zero shift value.
- 10 Turn off the maintenance mode to end the calibration.

7.5 Basic (reference) sensitivity calibration

This calibration is conducted to make Sens. factor updated when measurement electrodes are replaced with new ones. The slope changes to 100 %.

No error check is conducted during this calibration, so perform calibration properly. Calibration uses either an actual sample expected to be used in the process or a standard solution. See “7.2 Slope calibration” for information on preparation of calibration solution.

[How to perform basic reference sensitivity calibration]

- 1 Turn on the maintenance mode.
- 2 Feed calibration solution into the flow cell with reagent by the liquid flow pump. Confirm that the electrode unit is ready for the measurement. Use the result of the manual analysis as calibration value.
- 3 Press CAL on Main screen to enter the calibration menu.
- 4 Select [basic sensitivity calibration] in the menu list of Calibration others.
- 5 Confirm the reading is stable. Press [check stability].
- 6 When a message appears to show that the reading is stable, enter a calibration value. Press [Next]. As the calibration value, enter the manually acquired value in the step 2 above.
- 7 Check the calibration result. Press [Accept] to update Sens. factor in the calibration parameter. Slope is 100%.
- 8 To exit the calibration, turn off the maintenance mode.

7.6 Zero calibration with circuit open

Perform the calibration while keeping the Electrode unit in a measurement position.

- 1 Press CAL on Main screen to enter the calibration menu.
- 2 Select [Zero cal. with circuit open] in the menu list of Calibration others.
- 3 Confirm the reading is stable. Press [check stability].
- 4 Once a message appears to show that the reading is stable, confirm that the calibration value is zero. Press [Next].
- 5 Check the calibration result. Press [Data update] to update “zero” of calibration parameter.

7.7 Calibration Error

When executing calibration items except for Basic sensitivity calibration, if a calibration result is abnormal, the calibration error is displayed, and the calibration result is discarded. The acceptable ranges are as follows:

Zero: -3 to 3 μA

Slope: 25 to 400%

8. MAINTENANCE

This chapter describes the inspection of the electrode unit and the maintenance required to maintain the RC800D operation in good condition.

For trouble shooting, read “9. TROUBLESHOOTING”.

■ Maintenance for the accurate measurement

Regular maintenance is necessary to prevent contamination on the electrode that leads to measurement error.

Table 8.1 below shows the principal inspection/maintenance items and recommended maintenance cycle to keep the good operating condition.

Table 8.1, Table 8.2, and Table 1.1 set the recommended cycle for implementing preventive maintenance for long-life products, but do not guarantee against any accidental failure.

Actual maintenance intervals must be determined by individual operating conditions.

Table 8.1 Inspection and Maintenance Items, Recommended Implementation Cycle

Inspection/Maintenance Items	Recommended Cycle	Reference section
Replenishment of reagent	—	8.1 Replenishment of reagent
Polishing of the measurement electrode	Monthly	8.2 Polishing the measurement electrode
Lubrication of liquid flow pump drive	Monthly	8.3 Lubrication of the liquid flow pump drive
Calibration	Monthly	8.4 Calibration
Beads cleaning	Once every three months	8.5 Cleaning the Beads and Flow cell
Electrode unit inspection/replacement	Once every three months to a year (depending on the parts)	8.6 Checking the electrode unit, Replacing Parts
Replacement of Bellofram and valve sheet	Once every six months	8.7 Replacement of valve sheet and Bellofram in the liquid flow pump
Check liquid flow pump delivery rate	when replacing Bellofram in the liquid flow pump	8.8 Liquid flow pump delivery rate confirmation and adjustment
Replacement of the measurement electrode	Once a year	8.2 Polishing the measurement electrode
Replacement of beads	Once a year	8.5 Cleaning the Beads and Flow cell, (3.4 Filling beads)
Replacement of activated charcoal filter	Once a year	8.9 Replacement of Activated Charcoal Filter
Check the filter sand	—	8.10 Maintenance of the sand filter (3.5 Checking sand filter)
Replacement of fuse	—	8.11 Replacement of fuse

Note: The maintenance cycle should be determined according to the individual operating conditions and the characteristics of contamination.

8.1 Replenishment of reagent

Reagents are consumed at a rate of 2 to 2.4 liters a day. When the amount of reagent in the reagent tank is small, replenish the reagents prepared according to “3.2Preparation of reagents”. For reagent replenishment, prepare the reagent in another tank and put the reagent into the reagent tank. If you prepare the reagent directly in the reagent tank, consider the amount of remaining reagent and add some pure water as accurately as possible.

Also, when you prepare a reagent, be sure to put it in maintenance mode and stop the operation of the liquid flow pump from the solenoid valve/pump operation screen.

8.2 Polishing the measurement electrode

The measurement electrode constantly rotates at 600 rpm and is automatically polished with beads. However, this does not completely prevent adhesion of contamination; contamination gradually accumulates on the electrode surface over time.

A contaminated electrode surface is a cause of measurement error. The degree of the measurement error increases depending on the amount of contamination. Therefore, the electrode surface must be polished using abrasive (alumina, accessory) to remove such contamination before measurement error exceeds the allowance. When replacing electrodes, use the new electrode after polishing the electrode surface.

Note: It is recommended to polish the measurement electrode every month. Every two or three months may be sufficient in some cases; the required polishing frequency differs with the quality of the samples. After polishing the measurement electrode surface, conduct calibration with running-in operation.

- (1) Stop the measurement electrode rotation and place the electrode unit in the maintenance position (Figure 1.4).
Remove the electrode unit cover.
- (2) Remove the measurement electrode.
Insert a 2 mm-hex wrench (accessory) through the gap under the rotating contact into the round hole to fix the shaft so that the shaft will not turn.
Remove the measurement electrode by turning it counterclockwise. At this time, do not give an impact to the rotating contact.

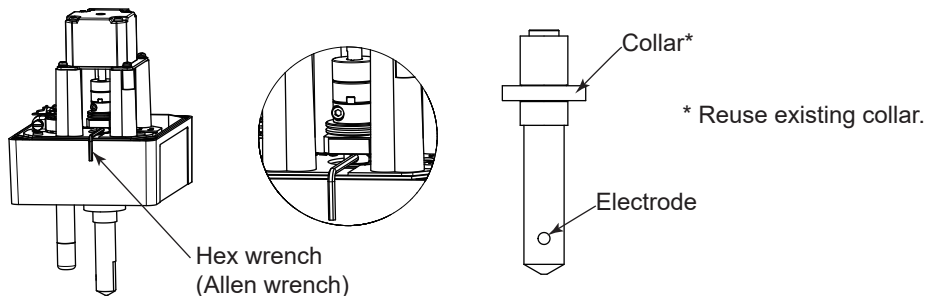

Figure 8.1 Polishing Electrode unit

- (3) Polish the electrode surface as follows.
 - Spread the provided abrasive (alumina) onto dampened gauze or cotton swabs.
 - Clean the electrode surface thoroughly using the gauze or the cotton swabs so that any contamination such as oil and grease is completely removed.
 - Wash off any abrasives adhering to the electrode in clean running water.
 - After polishing and cleaning, confirm that contamination has been completely removed.
 - The clean electrode surface must be uniformly wetted.
- (4) Put the measurement electrode back onto the driven shaft.
Just like when you remove it, insert the hex wrench into the round hole to fix the shaft so that it does not rotate. Screw the measurement electrode into it tightly. At this time, be careful not to touch the gold alloy surface. In case you do, polish it again.
- (5) After attaching the measurement electrode, attach the electrode unit cover and put it back to the measurement position (Figure 1.3).

● When the electrode has become corrugated or deformed

Polish the electrode surface by following the instructions and adjust the volume of beads when the electrode has become corrugated or deformed from the original circle: about 3 mm in diameter.

1. Polish the electrode surface with sandpaper (about #600) until the surface becomes flat and round.
2. Polish it with sandpaper (about #2000), and lastly with polishing powder (alumina).
3. Rinse it off with water. Check the electrode is clean.

Reduce the volume of beads if the electrode has deformed greatly. At this time, the beads should be filled up to about 6 mm above the notch of the bead case with the measurement electrode being inserted in the bead case.

8.3 Lubrication of the liquid flow pump drive

Lubricate only the bearings of the lever support block, as shown in Figure 8.2. Lubricate a few drops of the supplied lubricating oil (engine oil) from the lubrication port of each block. Lubricate once a month.

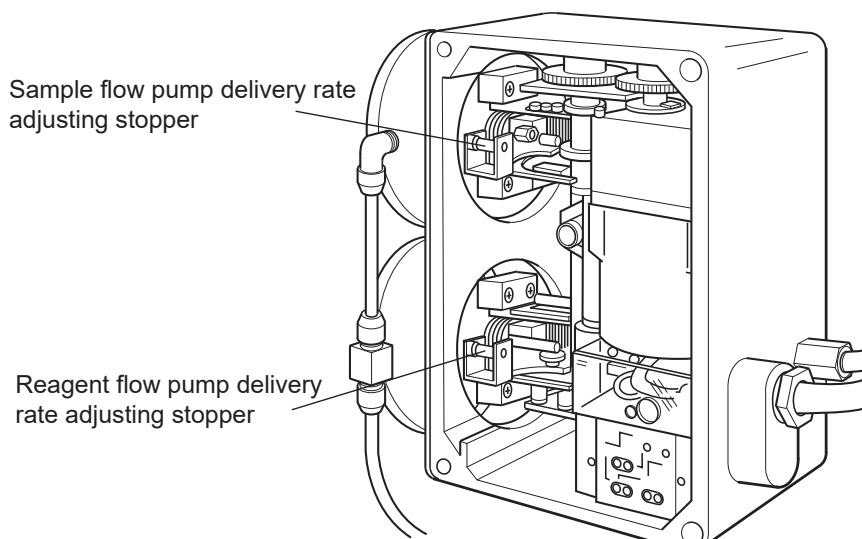

Figure 8.2 Liquid flow pump drive

8.4 Calibration

We recommend that you calibrate once a month. Be sure to calibrate if the instrument has been out of operation for a long time or after the measurement electrode has been polished. For calibration procedure, follow the explanation described in “7. CALIBRATION”.

8.5 Cleaning the Beads and Flow cell

Contaminated glass beads reduce the cleaning effects of the measurement electrode.

Clean the glass beads periodically. Clean the flow cell at the same time.

Follow the procedure below to clean the beads and the flow cell.

- (1) First turn on Maintenance mode then stop the measurement electrode.
- (2) After placing the electrode unit to the maintenance position (Figure 8.3), turn off the liquid flow pump from the solenoid valve pump operation screen to stop it.
- (3) With the beads in it, take out the bead case with the bead case cover together from the flow cell. The bead case cover is tightly attached, so be careful not to tear it.

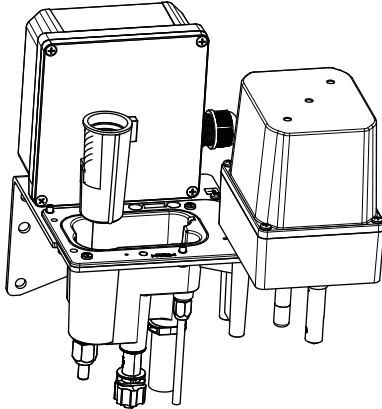

Figure 8.3 Maintenance position of the electrode unit

- (4) Clean the flow cell.
Using a brush and neutral detergent, sufficiently remove contamination from the flow cell. For adhesion of manganese or iron, use diluted hydrochloric acid. Finally, wash off the detergent from the flow cell using water.
Note: Never attempt to use organic solvent for cleaning.
- (5) Pour the beads into another container. Remove contamination using diluted hydrochloric acid, and sufficiently wash the beads with water.
- (6) Clean the bead case, and the bead case cover.
For the bead case and bead case cover, clean both in the same manner as flow cell cleaning in step (4).
Note: The bead case cover may turn whitish during prolonged use; however, it causes no functional problem.
- (7) Set the bead case cover onto the bead case and pour the cleaned beads into the bead case. If the beads have obviously become smaller in size (much smaller than a diameter of 1.7 to 2.3 mm), replace them with new ones.
Note: The glass beads are worn in long-term use, thereby reducing the ability of polishing measurement electrode. The beads should be entirely replaced once every year.
For optimum polishing, refer to "3.4 Filling beads" and replenish an appropriate amount of beads.
(If the electrode is extremely worn out, the polishing ability may not be recovered by only replenishing the case with the same amount of beads which was just reduced)
- (8) Return the electrode unit in the measurement position (Figure 1.3).
- (9) Rotate the measurement electrode. Turn off the maintenance mode to exit the maintenance.

8.6 Checking the electrode unit, Replacing Parts

The motor assembly in the electrode unit and the driven shaft assembly have finite life. If conditions of use or environment are outside of specifications, their life may be shorter than would otherwise be expected.

Check periodically whether the electrode unit is operating normally. To check if abnormal or not, refer to "Main Check List"; for a simple check whether calibration and the like is abnormal, refer to "Auxiliary Check List". Alternate these checks for best results.

When such parts that are subject to aging have been operated for their "recommended lifetime", it is recommended that you replace them even if you feel that there is still life left in them.

Table 8.2 shows a list of parts. We recommend that you should check and replace them if necessary.

Table 8.2 Parts recommended for periodic checks (maintenance) and replacement

The recommended replacement cycle is a guideline for replacement and does not guarantee this period.

Name	Recommended Main check cycle	Recommended replacement interval
Rotating contact	—	Yearly
Coupling	6 months (Auxiliary check: 3 months)	3 years (operating time)
Driven shaft assembly	6 months (Auxiliary check: 3 months)	3 years (operating time)
Motor assembly	6 months (Auxiliary check: 3 months)	3 years (operating time)

* Rotating contact does not require inspection.

8.6.1 Replacement of Rotating contact

CAUTION

Never touch Rotating contact except when replacement is performed.

When you hold Rotating contact, pinch it with two fingers and never touch the center contact part. Never drop it or gives a shock.

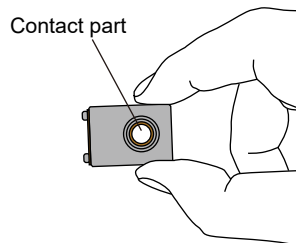

CAUTION

The storage limit for Rotating contact is 1 year after the purchase, considering degradation of the lubricant used inside. Store it at room temperature and keep it away from direct sunlight.

[Maintenance procedure]

Rotating contact basically does not need inspection. Never replace the rotating contact except when the replacement is performed. Replace it every year.

[Replacement procedure]

- (1) Turn off the switch provided on the power line to stop the operation of the residual chlorine sensor.
- (2) Place the electrode unit in a maintenance position (Figure 1.4) and remove the electrode unit cover.
- (3) Loosen the two fixing screws of the coupling with a nominal-2 mm hex wrench (accessory). Remove the connector of the motor. Remove the fixing screws (4 screws) and the ground terminal. Remove motor assembly and the coupling

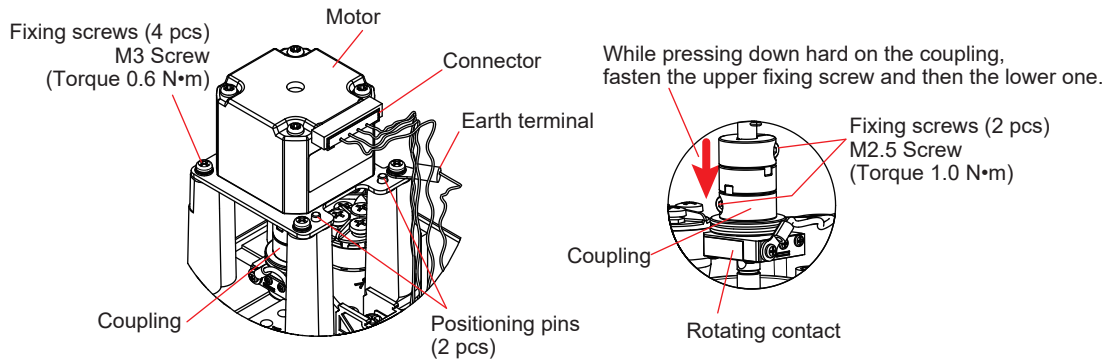

Figure 8.4 Replacement of rotating contact 1

- (4) Insert the nominal-2 mm-hex wrench (accessory) into the round hole of the driven shaft. Remove the retainer of the rotating contact with a flat-blade driver. Remove one screw which fixes the rotating contact on the terminal block. Remove the wiring terminal of the rotating contact and pull out the rotating contact from the driven shaft.

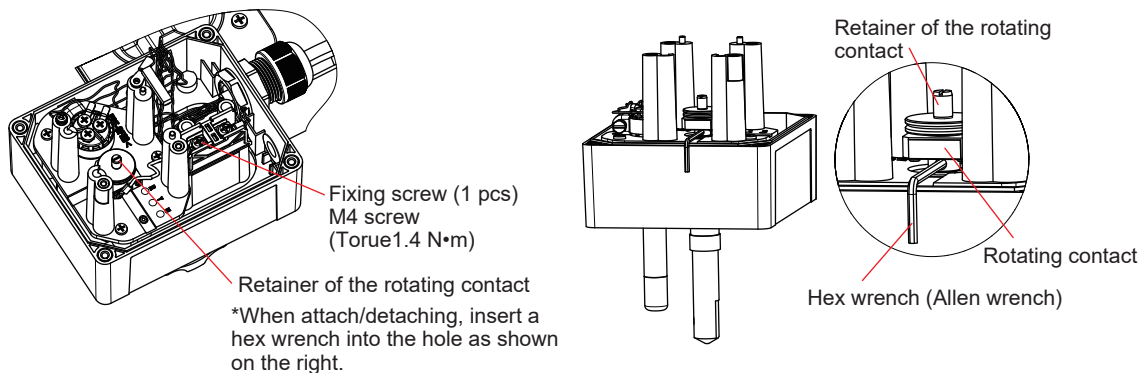

Figure 8.5 Replacement of rotating contact 2

- (5) Mount a new rotating contact on the driven shaft. Insert the hex wrench into the round hole. Fasten the retainer that fixes the rotating contact with the flat-head screwdriver.
- (6) Place the coupling back on the rotating contact retainer. At this time do not fasten the fixing screws of the coupling.
- (7) Insert the shaft of the motor assembly into the hole above the coupling. Position the two female pins at the holes of the motor assembly and fasten them with four fixing screws. Fix the ground terminal together with screws. Install the motor connector.
- (8) Tighten the coupling with the two fixing screws in the order shown in the figure while pressing the coupling down strongly with your fingers. Insert the hex wrench (Allen wrench) into the hex head of the screw. Press and turn it until it is fully tightened. Loose insertion or tightening may deform the head of the screw and make it impossible to fix the coupling.

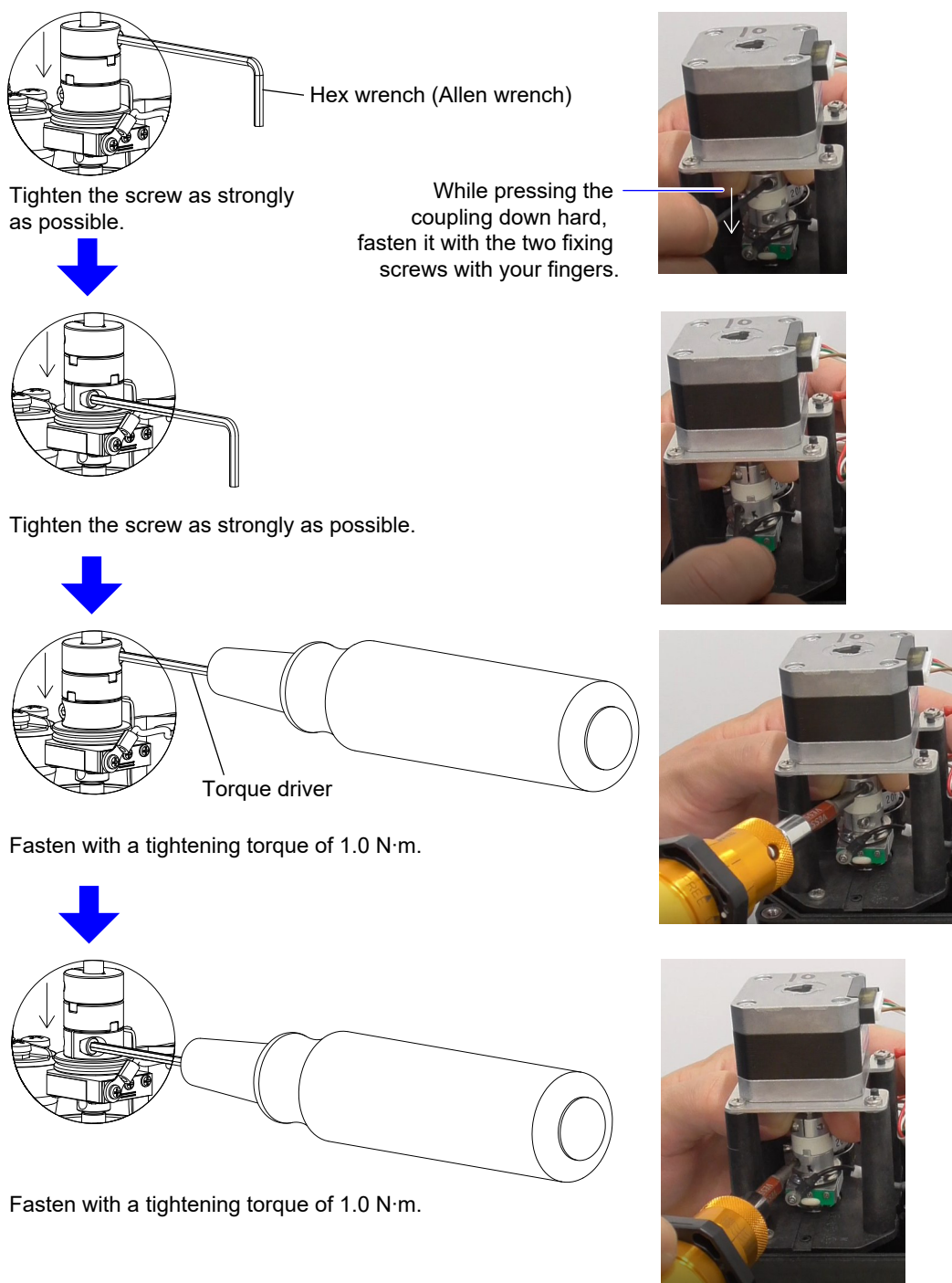

Figure 8.6

- (9) Turn on the power to the FC800D and check for any abnormal sound. If you hear a rattling sound, the operation described in (8) may be inadequate. Loosen the two coupling fixing screws and perform the procedure (8) again.

NOTE

Be sure to follow the order and procedure of (7) and (8) to minimize the rotational runout of the shaft.

CAUTION

When you shut the electrode unit cover, be careful not to get the cables caught that run inside the analyzer.

8.6.2 Maintenance/ Replacement of Driven Shaft Assembly

[Maintenance procedure]

At zero calibration time, check the following (once in three months recommended) by operating the electrode unit. (recommended cycle is 3 months)

- Check if noisier than usual sound is generated, or if vibration or non - continuous noise is generated.
If the sound is abnormal, it may be due to a defective bearing in the driven shaft assembly. (or other causes such as a motor problem) Stop the operation of the electrode unit and check for friction on the driven shaft. See Six-monthly check below.
- Check the driven shaft and the measurement electrode for runout. The runout is likely to be occur due to a worn bearing on the driven shaft assembly. Stop the operation of the electrode unit and check the backlash between the driven shaft and the bearing. Also, stop the operation of the electrode unit once every six months and perform the next inspection.
- Turn the driven shaft by hand. Confirm that it rotates smoothly as usual and no backlash is felt.

[Replacement procedure]

If the bearing has defects, replace the entire driven shaft assembly. In principle, this should be done by Yokogawa's service facility.

If the user should replace it, the procedure would be as follows:

<How to disassemble>

- (1) Shut off the power fed to the RC800D. Place the electrode unit in the maintenance position then remove the cover from the electrode unit.
- (2) Remove the measurement electrode. (Refer to "8.1 Replenishment of reagent")
Remove the parts in the following order: Motor assembly - Coupling - Rotating contact.
- (3) Remove the reference electrode.

First, disconnect the three wires. (T1, T2 and RE)

Next, loosen the clamp (fixing the electrode onto the holder) with flat blade screwdriver and pull it up.

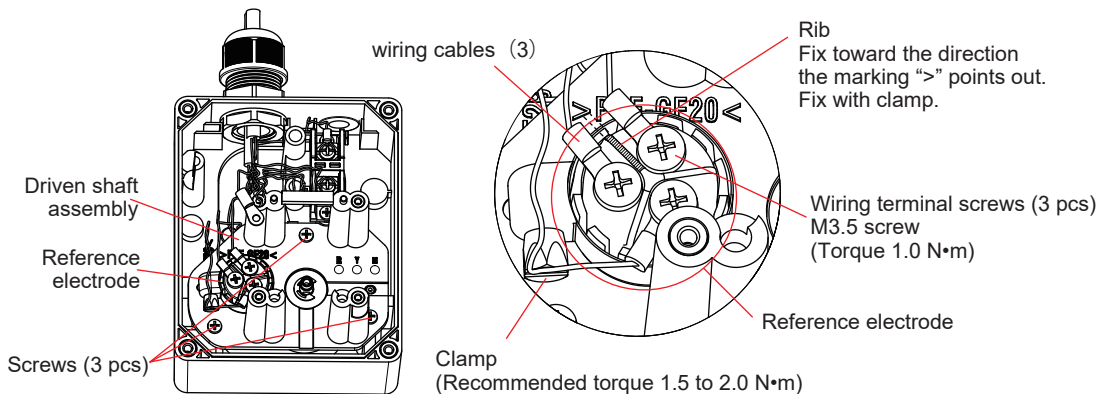

Figure 8.7 Replacement of Driven shaft assembly 1

- (4) Remove the three M3 screws and remove the driven shaft assembly. A rubber cover and an O-ring are attached to the insertion part at the base of the electrode holder. Replace them with a new rubber cover and O-ring, which are supplied with the driven shaft assembly. The clamp that fixes the reference electrode are to be reused.

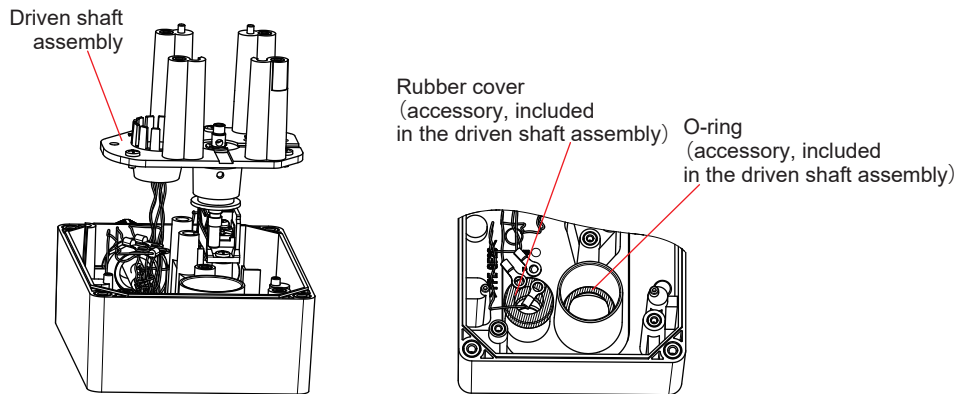

Figure 8.8 Replacement of Driven shaft assembly 2

The following steps after (5) explain how to reassemble the unit parts. Keep the following in mind when you reassemble the parts.

- Clean any dirt off parts before reassembling.
 - Make sure that measurement electrode does not make contact with the base when reassembling.
- (5) Set a new rubber cover and O-ring. Press down the shaft of the new driven shaft assembly. Position them at the two points shown in Figure 8.9. Fasten them with three fixing screws.

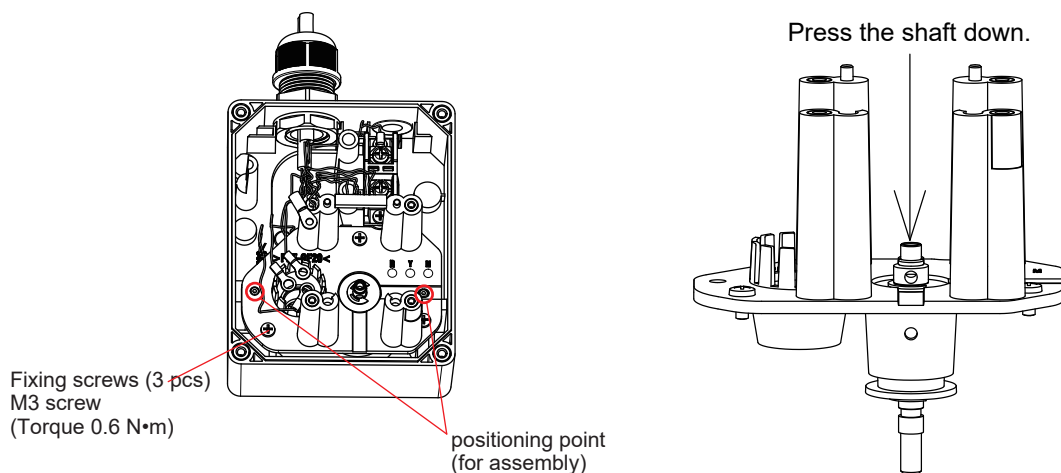

Figure 8.9 Replacement of Driven shaft assembly 3

- (6) Install the reference electrode
Install the reference electrode at the position shown in Figure 8.7, and fix it with a clamp according to the position shown in Figure 8.7. Then, provide the wiring with three cables.
- (7) Install the parts in the following order: Rotating contact - Coupling - Motor assembly. (Refer to “8.6.1 Replacement of Rotating contact”)
- (8) Mount the measurement electrode. (Refer to “8.1 Replenishment of reagent”)

This completes the replacement procedure. Feed power to RC800D. Check that the driven shaft rotates smoothly and there is no abnormal noise like vibration or intermittent sound.

8.6.3 Maintenance/Replacement of Motor/Coupling

[Maintenance procedure]

At zero calibration time, operate the electrode unit and check the following. (once in three months recommended)

- Is there any irregularity in the rotation speed of the drive shaft? If yes,
Replace motor assembly.
Recheck there's no irregularity in the rotation speed of the drive shaft.
If no irregularity reappears, inspect the driven shaft assembly.
 - Is there any axial runout rotation observed on the tip of the measurement electrode? Is there any abnormal noise coming from the electrode unit? If yes,
The steps described in "8.6.1 Replacement of Rotating contact" (6)(7)(8) might not be completed correctly.
Loosen the two fixing screws of coupling. Retry the steps described in "8.6.1 Replacement of Rotating contact"
- Is there any abnormal sound coming from the motor? If yes,
Check the motor assembly. (In principle, this should be done by Yokogawa.)

[Replacement Procedure]

Replace the motor or coupling when replacing the rotating contact as described in "8.6.1 Replacement of Rotating contact"

8.7 Replacement of valve sheet and Bellofram in the liquid flow pump

The bellofram and valve sheet in the liquid flow pump should be replaced with new ones once every 6 months, even if there are no particular abnormalities. The next figure shows the internal structure of liquid flow pump.

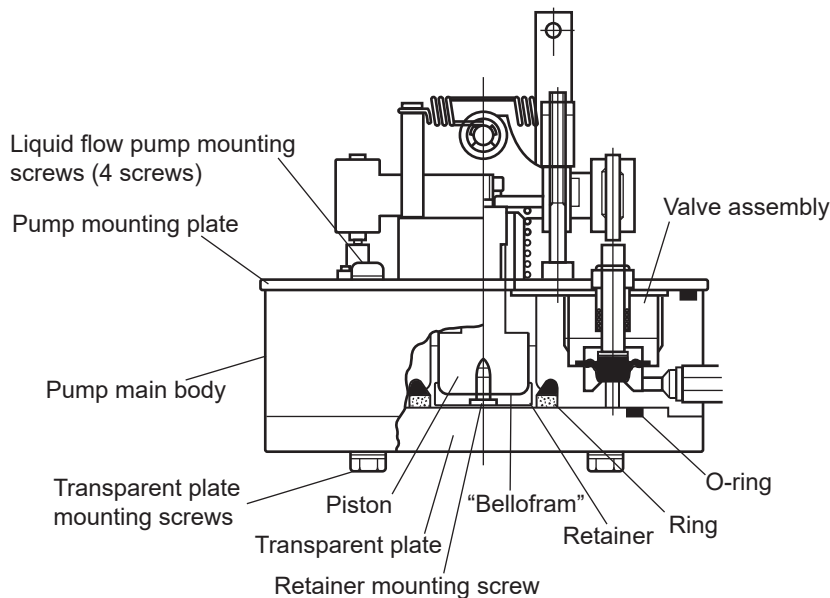

Figure 8.10 Internal structure of the liquid flow pump

8.7.1 Replacement of bellofram

To replace the bellofram, follow the procedure below.

- (1) Turn on the maintenance mode and stop the operation of the liquid flow pump from the solenoid valve/pump operation screen. Take measures to prevent the reagent from flowing out of the reagent tank.
- (2) Remove the transparent plate of the liquid flow pump. Loosen the four screws on the front.
- (3) Remove the ring that holds the flange of the bellofram.
- (4) Remove the retainer screwed to the piston.
- (5) Remove the bellofram in use and install a new bellofram. To install, first press the flange of the bellofram with a ring. Use the attached tool and fold the bellofram so that it covers the piston (Figure 8.11).

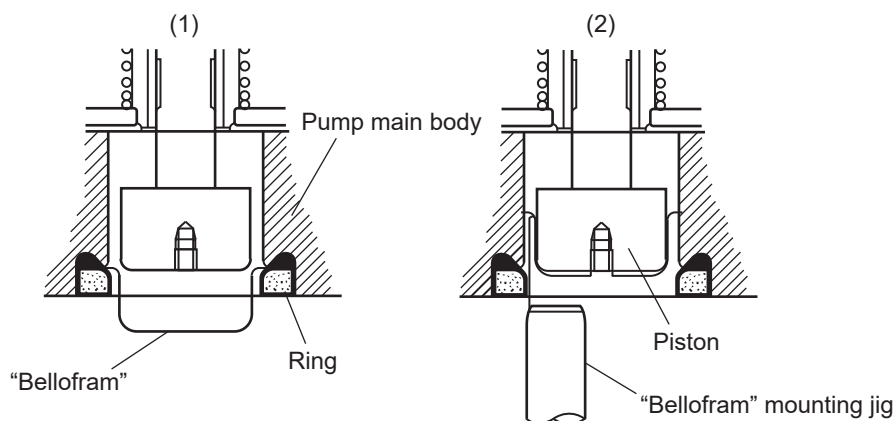

Figure 8.11 Installation of the bellofram

- (6) Reassemble the disassembled parts.

When the maintenance is finished, turn on the liquid flow pump from the solenoid valve/pump operation screen. Make sure the liquid flow pump runs without problem. Turn off the maintenance mode after the measured value stabilizes.

8.7.2 Replacement of the valve sheet

To replace the valve sheet, follow the procedure below.

- (1) Remove the liquid flow pump together with the pump mounting plate.
First, turn on the maintenance mode and stop the operation of the liquid flow pump from the solenoid valve/pump operation screen.
Next, remove the piping connected to the joint on the delivery side of liquid flow pump, and the piping connected to the suction side joint and delivery side joint of the reagent liquid flow pump.
Then loosen the six screws that secure the plate. When removing the piping, take measures to prevent the reagent from flowing out of the reagent tank.
- (2) Remove the liquid flow pump from the plate.
First, remove the bellofram according to Section 8.7.1.
Next, disconnect the pipe connected to the pump and loosen the four screws on the back of the plate.
- (3) Remove the valve assembly.
Use the exclusive tool (accessory) to turn the valve assembly screwed into the pump body counterclockwise.

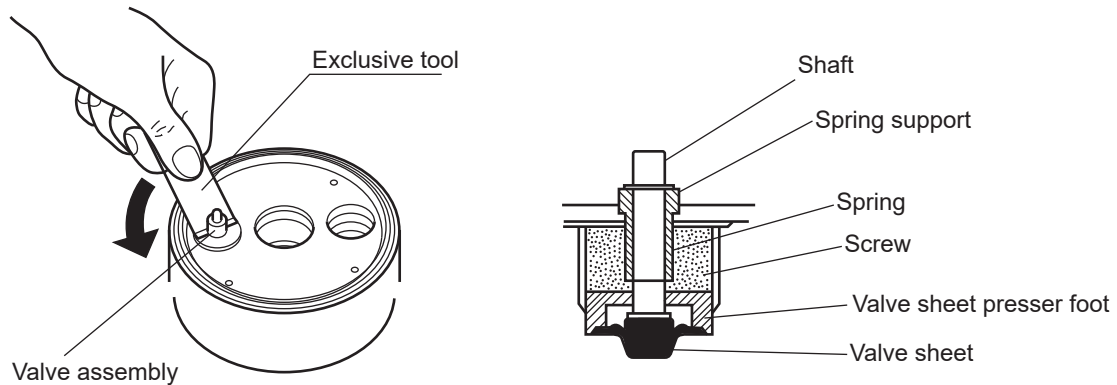

Figure 8.12 How to remove the valve assembly, internal structure

- (4) Remove the valve sheet in use from the shaft and install a new valve sheet. Make sure that the valve sheet is properly fitted to the shaft. Also, install the valve sheet so that the flange does not protrude from the groove of the valve sheet retainer.
- (5) Fully screw the valve assembly into the pump body.
- (6) Install the liquid flow pump in the pump mounting plate and then mount this plate in the case. When assembling, make sure that the drain hole of the liquid flow pump is downside.
- (7) Incorporate parts for liquid flow pump such as belloframs that were removed in the procedure (2).
- (8) Reconnect the removed piping.
- (9) Allow the reagent to flow out of the reagent tank. From the solenoid valve/pump operation screen, turn on the liquid flow pump and check that the operation is normal. Turn off the maintenance mode after the measured value stabilizes.

8.8 Liquid flow pump delivery rate confirmation and adjustment

When replacing the bellows or valve sheet, check the delivery rate of the liquid flow pump. The confirmation method conforms to "3.10 Checking pump delivery rate". If it is not within the specified delivery rate range, change the position of the stopper on the pump drive mechanism to adjust the delivery rate.

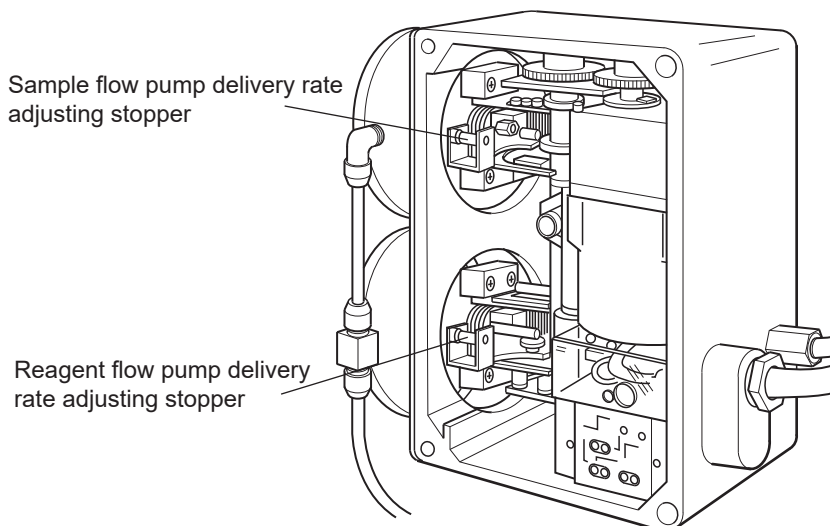

Figure 8.13 Stopper for delivery rate adjustment

- (1) Turn on the maintenance mode and stop the operation of the liquid flow pump from the solenoid valve/pump operation screen.
- (2) Shift the position of the corresponding stopper.
Loosen the locknut and turn the stopper clockwise to reduce the flow rate, or counterclockwise to increase the flow rate.
- (3) Check the delivery rate, and if it is not yet within the specified flow rate range, repeat the procedure (2).
- (4) When the delivery rate reaches the specified range, make sure that the locknut is sufficiently tightened, and restart the operation.

8.9 Replacement of Activated Charcoal Filter

Stop the supply of measurement water with the original valve.

- (1) Remove the filter case by turning it in the direction shown in Figure 8.14.
- (2) Clean the inside of the filter case with a brush.
- (3) Replace the activated charcoal filter with a new one.
- (4) Assemble in the reverse procedure.
- (5) Turn on SV6 and let zero water flow for 30 minutes or more. At this time, make sure that there is no water leakage.
- (6) Confirm that the indicated value is near zero.

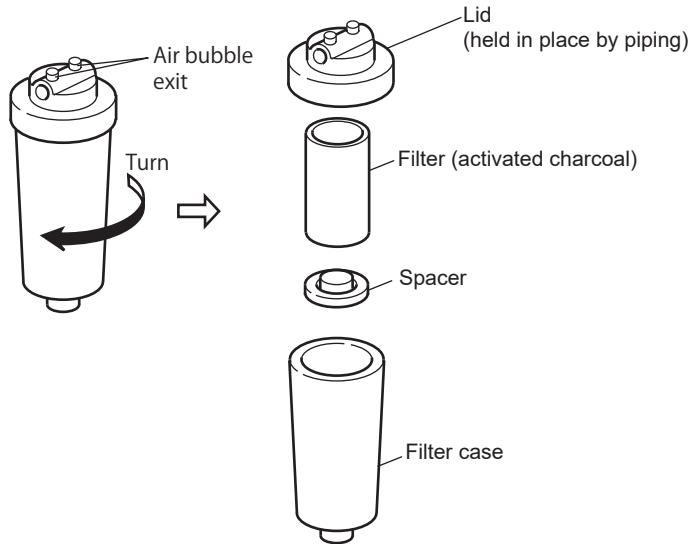

Figure 8.14 Replacing Activated Charcoal Filter

8.10 Maintenance of the sand filter

If the sampling device specification requires a residual chlorine meter of -2 □ or -3 □, inspection and maintenance of the sand filter have to be conducted. Perform the following inspections and maintenance.

8.10.1 Inspection of filter sand surface

Check if there are any mudballs on the surface of the filter sand. If mudballs are generated, crush the balls into small pieces with a stick and make sure that the crushed flocs flow out during sand filtration backwashing. Also, prolong the cleaning time or shorten the cleaning cycle to prevent the recurrence.

8.10.2 Check the amount of filter sand in the sand filter

Flock and other substances accumulated in the sand filter is discharged to the outside of the filter by water jet cleaning that is automatically performed at regular intervals.

If this cleaning cycle is improper, the flocs will build up as a thick layer, and the cleaning water during backwashing may lift the entire sand and mix it with the flocs, and the filter sand may also be discharged. It also reduces the amount of filter sand in the filter.

When the filter sand is reduced, the floc layer lowers the filtration rate, which delays the response. The reduced sand may also lead to an increase in measurement error due to chlorine absorption on the flocs.

If the filter sand is reduced, remove the top lid of the filter tube and replenish the sand to the position of the scale <10> on the filter tube (see Figure 8.7).

8.10.3 Inspection of discoloration of filter sand in sand filter

Manganese and iron contained in the sample can contaminate the flow cell of the residual chlorine meter. The filter sand adsorbs to the contaminants and prevents the contaminants from adhering to the flow cell. However, if manganese or iron is adsorbed enough to discolor the entire filter sand layer, replace it with new filter sand according to the following procedure.

[Replacement Procedure]

- (1) Close the sample valve and the cleaning water valve to stop the supply of the sample and the cleaning water.
One sand filter -2□ sample valve: V3, cleaning valve: V4
DBL sand filters -3□ sample valve: V3 or V4, cleaning valve: V6
- (2) Remove the top lid of the sand filter and take out the filter sand by hand or container. At this time, some filter sand may remain.
- (3) If the inner wall of the filter tube is black due to manganese or dark brown because of iron, clean it with dilute nitric acid.
- (4) Replenish new filter sand up to the position of the scale <10> on the filter tube.
- (5) Replace the top lid of the sand filter and open the sample valve and the cleaning water valve. Start supplying sampler and cleaning water.

8.10.4 Replacement of the sand filter

At the bottom of the sand filter, there is a filter to prevent the filter sand from coming off. (See Figure 8.15)

If the filter is clogged and the specified flow rate cannot be obtained, replace the filter according to the following procedure.

[Replacement Procedure]

- (1) Close the sample valve and the cleaning water valve to stop the supply of the sample and the cleaning water.
One sand filter -2□ sample valve: V3, cleaning valve: V4
DBL sand filters -3□ sample valve: V3 or V4, cleaning valve: V6
- (2) Remove the top lid of the sand filter and remove as much filter sand as possible by hand or in a container.
- (3) Loosen the four fixing screws on the bottom of the sand filter and remove the sand filter.
- (4) Loosen the set screws (4) at the bottom of the filter tube and pull out the cleaning water inlet part downward to remove the filter. If filter sand remains in the filter tube, the sand falls along with the filter.
- (5) Replace the filter, and put the cleaning water inlet back in place, and secure with fixing screws. At this time, wash off the filter sand sufficiently. If it gets scratched, it may cause leakage.
- (6) Return the sand filter to its original position and secure it with the fixing screw.
- (7) Replenish the filter sand up to the position of the scale <10> on the filter tube.
- (8) Replace the top lid of the sand filter and open the sample valve and cleaning water valve. Start supplying sample and cleaning water.

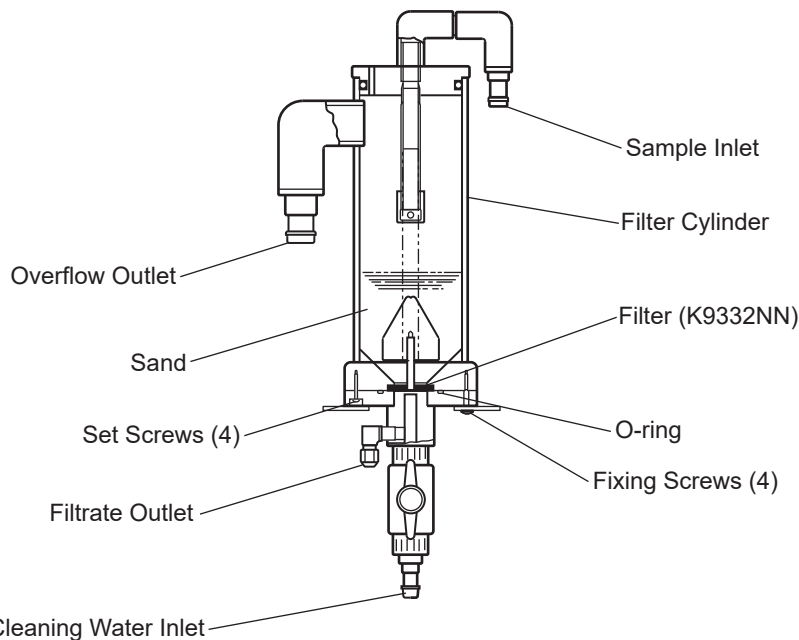

Figure 8.15 Inspection/Maintenance of the sand filter

8.11 Replacement of fuse

If the fuse blows, replace it.

The RC800D fuse is located inside the smart unit.

CAUTION

Make sure the power is off before replacing the fuse. Do not replace the fuse while the power is on.

■ Replacement of fuse on Smart unit

Be sure to use A1633EF for the fuse of the smart unit.

- (1) Loosen the four screws and open the relay box cover.
- (2) Remove one fuse cover.
- (3) Replace the fuse with a new one and attach the fuse cover.
- (4) Close the cover of the smart unit.

■ Replacement of fuse on Relay box

Be sure to use A1624EF for the fuse of the relay box.

- (1) Loosen the four screws and open the relay box cover.
- (2) Remove the two fuse holders.
- (3) Replace the fuse with a new one and attach the fuse holder.
- (4) Close the relay box cover.

■ Resuming operation

Turn on the power of the device. Warm up for at least 30 minutes before starting the measurement. Arrange the following fuses.

Table 8.3 Fuse (spare parts)

Name	Part No.	Description
Fuse	A1633EF	250V/2.5A for the smart unit
Fuse	A1624EF	250 V/3.15 A for the relay box The relay box uses two fuses.

9. TROUBLESHOOTING

9.1 When an error occurs

Table 9.1 RC800D Sensor Error List

Alarm Number	Name	Description and Remedy		NE107 (*1) Default	NE107 change
X600	EEPROM error	Instrument failure. Contact Yokogawa service.		F	Disable
X601	User param. read error			F	Disable
X602	Factory param. read error			F	Disable
X603	AD converter failure			F	Disable
X604	RAM failure			F	Disable
X605	Flash Memory failure			F	Disable
X608	Temperature sensor failure	Temperature sensor failure. Check sample temperature value. Check the reference electrode connection. Check the resistivity between T1 and T2 terminals.		F	Disable
X609	Motor driver failure	Motor driver of the measurement electrode failure Contact Yokogawa service		F	Disable
X60A	Sensor Communication error	No sensor is detected.	Check the power supply connection. Check the connection between the electrode unit and the converter.	F	Enable
X620	Wash/Cal. box error	Wash box setting error or the Relay box for solenoid valve failure.	Disable Wash box configuration	S	Disable
X640	Chlorine High	Chlorine concentration exceeds the high limit.	Check the chlorine concentration measured. Check the upper limit setting of the chlorine concentration.	S	Enable
X641	Chlorine Low	Chlorine concentration exceeds the low limit.	Check the chlorine concentration measured. Check the lower limit setting of the chlorine concentration.	S	Enable
X642	Temperature too high	The sample temperature is out of the range between 0.0 to 50.0°C. Control the sample temperature so that it falls within the range.		S	Enable
X643	Temperature too low			S	Enable
X644	Temperature comp. range over	The sample temperature for Temperature compensation is out of the range between 0.0 to 40.0°C. Control the sample temperature so that it falls within the range. Sample calculation cannot be correctly performed when this error occurs.		S	Enable
X645	pH comp. range over	pH value for pH compensation is out of the range between pH 5 to pH 9 pH comp. Sample calculation cannot be correctly performed when this error occurs.		S	Enable
X647	Meas. current range over	Diffusion current measured value is out of the measurable range. Check the setting of applied voltage.		S	Disable

*1: F: Failure, C: Function Check, S: Out of Specification, M: Maintenance required, N: Off
 Note : X of Alarm Number denotes Channel of sensors.
 1: sensor connection number 1-1
 5: sensor connection number 2-1

Alarm Number	Name	Description and Remedy	NE107 (*1) Default	NE107 change
X648	App. voltage error	Applied voltage is out of the range between -1.5 to 1.5V. Check the setting of applied voltage.	S	Disable
X649	Empty cell detection	The liquid is detected empty when the Empty cell detection is active. The error is canceled when a sample meeting the specification flows properly.	S	Enable
X64A	Motor driver high temp	The temperature of Motor driver is too high. Check the temperature of Motor	S	Disable
X64B	ME. rotating stop	Although the rotation of measurement electrode is ON, the motor does not rotate. Check the connection or the inside condition of the flow cell. Find the factor that inhibits the measurement electrode from rotating.	S	Enable
X64E	Auto Zero cal. result error	Auto Zero cal. result is not appropriate. Check status of the sampling system. Check zero water and operation of the solenoid valve	S	Enable
X64F	Auto Cal. Unstable	Stability check hits time out during Auto calibration. Check the operation of the solenoid valve. Check the setting related the stability check.	S	Enable

*1: F: Failure, C: Function Check, S: Out of Specification, M: Maintenance required, N: Off
 Note : X of Alarm Number denotes Channel of sensors.
 1: sensor connection number 1-1
 5: sensor connection number 2-1

Table 9.2 RC800D Analyzer Error Message List (Wash)

Alarm Number	Name	Description and Remedy	NE107 (*1) Default	NE107 Change
009E	Auto wash/cal. setting error	Auto wash/calibration is not properly set. Set the converter setting properly.	C	Enable
009F	Auto start date error	A past date is entered as a next start date of Auto wash/calibration, therefore the next Auto wash/ calibration cannot start. Set a future date as the start date.	C	Enable

*1: F: Failure, C: Function Check, S: Out of Specification, M: Maintenance required, N: Off

9.2 When No Error Indication Appears

There is a possibility that measurement has abnormalities without any error occurrence. Next table shows some possible causes. Solve the problems referring to the next table.

Table 9.3 Abnormalities, Their Possible Causes, and Remedies

Abnormalities	Possible Causes	Remedies
Measured value is abnormal.	<ol style="list-style-type: none"> 1. Sample volume is not sufficient. The reference electrode is not submerged in water completely. 2. The measurement electrode has stopped. 3. The measurement electrode has worn out. 4. The electrode unit has abnormality in the signal continuity. 	<ol style="list-style-type: none"> 1. Remove the clogging in the piping. Adjust the sample volume to the proper level. 2. Turn on the measurement electrode. Connect the electrode or motor coupling properly. 3. Replace the electrode with a new one. 4. Reconnect the measurement electrode. Replace the rotating contact with a new one. Wire signal cables properly.
Measurement error is large.	<ol style="list-style-type: none"> 1. The measurement electrode or beads are contaminated. 2. Zero and / or span has not been correctly adjusted. 3. Auto zero calibration abnormal. 	<ol style="list-style-type: none"> 1. Polish the measurement electrode. Clean the beads. (If you cannot sufficiently clean the beads or the electrode is worn out, replace them with new ones.) 2. Conduct zero and / or span calibration. 3. Replace activated charcoal filter. Remove the clogging in the ping for auto zero calibration.
Measured value fluctuates largely.	<ol style="list-style-type: none"> 1. The measurement electrode does not rotate at constant speed. 2. The rotating contact has abnormality. 3. The electrode unit has abnormality in the signal continuity 4. External noise interference exists. 	<ol style="list-style-type: none"> 1. Connect the measurement electrode or motors properly. 2. Replace the rotating contact with a new one. 3. Reconnect the measurement electrode. Wire signal cables properly. 4. Check the ground is wired correctly.
Response time is too long when the sample value changes.	<ol style="list-style-type: none"> 1. The liquid flow pump cannot deliver the sample and reagent properly. 2. Filtration performance of the sand filter is abnormal. 	<ol style="list-style-type: none"> 1. Replace the belloram or the valve sheet of the liquid flow pump. 2. Replace the filter sand and the filter in the sand filter.
Measured value does not vary.	<ol style="list-style-type: none"> 1. Sample water is not flowing in the flow cell. 2. Disconnection of electrode unit wiring. 3. No voltage is applied between the measurement electrode and the reference electrode. 	<ol style="list-style-type: none"> 1. Repair abnormality such as piping disconnection, clogged or liquid flow pump failure to normal condition 2. Repair the wiring. If disconnection occurs in an electrode, replace the electrode. 3. Connect between the smart unit and the electrode unit properly.

Appendix Automatic wash/Automatic calibration Sequence

The next diagrams show how the solenoid valve works during RC800D Automatic wash / Automatic calibration.

(1) For tap water/water distribution

In the case of a residual chlorine meter for water purification and distribution, the wash of the flow cell is not performed even if the automatic wash of the flow cell is turned on.

● Operation during automatic zero calibration

- The zero water side of SV3 opens when the automatic zero calibration starts. At this time, tap water passes through the activated carbon filter and is injected into the flow cell as zero water via SV3.
- Calibration is performed after the Waiting time for calibration has elapsed. The calibration time in the figure is the total time of the automatic stabilization check and the time when zero calibration is performed after checking reading stable.
- After the calibration time has elapsed, the head tank side of the SV3 switches to OPEN, and the calibration becomes recovery state. After the calibration Recovery time has elapsed, the measurement is restarted.

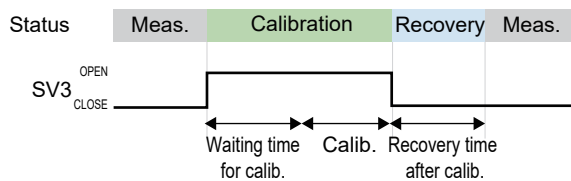

(2) For raw water measurement One sand Filter

In the sand filter 1-cylinder type, the automatic flow cell wash function, automatic sand filter wash function, and automatic calibration function can be enabled / disabled respectively. Turn on the wash and calibration sequence, and select one among: automatic flow cell wash / automatic sand filter wash function / automatic calibration function that you want to perform and turn it on.

At the timing of automatic wash, automatic flow cell wash and automatic sand filter wash operate at the same time. When the automatic wash function is ON and the sand filter wash function is ON, the total time from the start of automatic wash to the end of Recovery time after wash is “Washing time for detector + Recovery time after wash” or “Washing time for detector + Recovery time after wash + 7 seconds (*1)”, whichever is longer.

(*1) For the detail description, see the next section “Operation of auto sand filter wash”.

● Operation during the automatic flow cell wash

- SV2 opens when automatic wash starts. During the flow cell wash time, cleaning water is poured into the flow cell.
- After the Washing time for detector has elapsed, SV2 closes. After the Recovery time has elapsed, the measurement will resume.

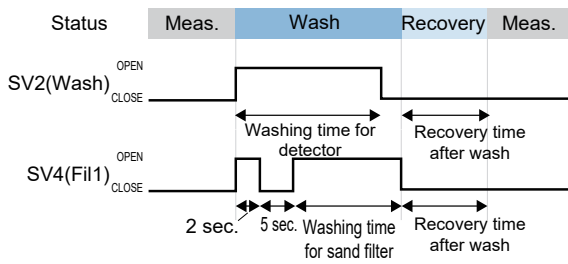

● **Operation during the automatic sand filter wash**

- When the automatic wash starts, the SV4 first opens for 2 seconds, then closes SV4 for 5 seconds. This process prevents the filter sand from spilling.
- After 5 seconds, SV4 opens again and closes after the Washing time for sand filter has elapsed.
- After the SV4 is closed and the Recovery time after wash elapses, the washing the sand filter is completed.

● **Operation during the automatic zero calibration**

When performing automatic zero calibration, the zero calibration is performed after cleaning the flow cell. In the cleaning that accompanies automatic calibration, the sand filter washing is not performed even if the automatic sand filter washing function is enabled.

- At the timing of starting automatic zero calibration, the flow cell is first cleaned. SV2 opens and the raw water is injected into the flow cell.
- After the Washing time for detector has elapsed, SV2 closes and moves to the calibration state.
- When the calibration state starts, SV3 opens and zero water is injected into the flow cell.
- After the Waiting time for calibration has elapsed, zero calibration is performed. The calibration time in the figure is the total time of the automatic stabilization check and the time when zero calibration is performed after checking reading stable.
- After the calibration is completed, SV3 closes and the Recovery time after calibration starts. After the Recovery time after calibration has elapsed, the measurement is restarted.

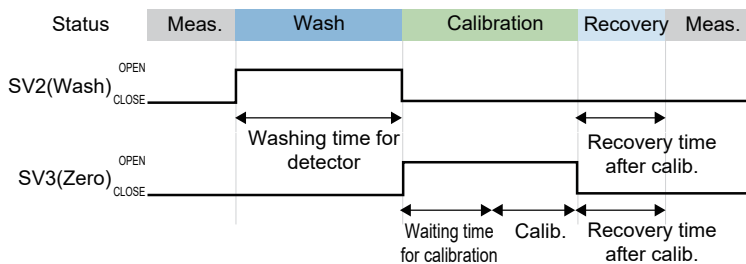

(3) For raw water measurement DBL sand filters,

In the case of the sand filtration 2-cylinder type, automatic sand filtration wash is performed regardless of the measurement / automatic wash / automatic calibration status. The sample is measured in the flow cell after passing through one of the sand filter tubes. Automatic sand filter wash is carried out on the sand filter tube that has not been measured. The sand filter tube used for measurement changes every wash cycle.

● **Operation of automatic wash**

At the timing of an automatic-wash start, only automatic flow cell wash is performed.

- SV2 opens when automatic wash starts. During the Washing time for detector, cleaning water is poured into the flow cell.
- After the Washing time for detector has elapsed, SV2 closes.
- After the Recovery time has elapsed, the measurement resumes.

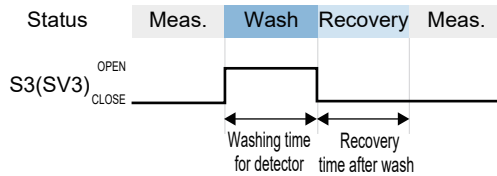

● **Operation during the automatic zero calibration**

First perform the flow cell wash, then conduct the automatic zero calibration.

- At the timing of starting automatic zero calibration, the flow cell is first cleaned. SV2 is opened and tap water is injected into the flow cell.
- After the Washing time for detector, SV2 closes and the calibration status starts.
- In the calibration state, the zero water side of SV3 is OPEN, and zero water is injected into the flow cell.
- After the Waiting time for calibration has elapsed, zero calibration is performed. The calibration time in the figure is the total time of the automatic stabilization check and the time when zero calibration is performed after checking reading stable.
- After the calibration is completed, the zero water side of SV3 closes, the sample side opens, and the calibration Recovery time starts. When the Recovery time after calibration has passed, the measurement resumes.

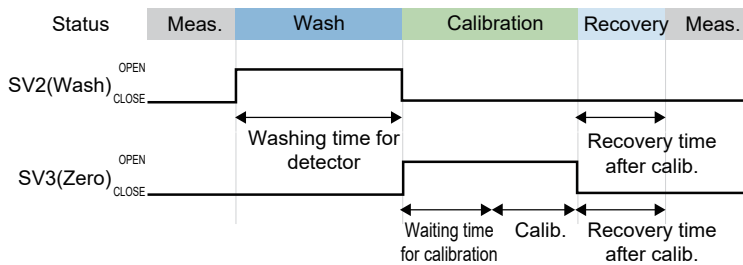

● **Operation during the sand filter wash**

Regardless of the state of the detector, the operation of switching between the two sand filter tubes and wash is continuously performed from the time when the power is turned on or the maintenance mode is turned off.

- SV6 and SV7 are turned on after the power is turned on (or when the maintenance mode is turned off). In this state, the flow cell is supplied with the measurement water that has passed through the two sand filter tubes. This is the preparation period for switching the sand filter tube, and this time is called the Cross time for DBL sand filter.
- After the Cross time elapses, SV7 remains OPEN, SV6 becomes CLOSE, and only the sample that passes through the F1 sand filter is measured.
- When the Washing interval for DBL sand filt. elapses, the F1 sand filter is washed and the sand filter tube leading to the flow cell switches from F2 to F1.
- At a wash of F1, SV4 is initially OPEN for 2 seconds and CLOSE for 5 seconds. SV4 is opened again and the inside of F1 is cleaned.
- SV4 closes after the Washing time for sand filter has elapsed. SV6 remains CLOSE during F1 wash. Therefore, the cleaning water doesn't flow into the flow cell. SV6 keeps closed until the end of the replacing time for DBL sand filter.

- SV6 opens after the Replacing time for DBL sand filter time elapses, and a preparation starts to be ready for FV1 to switch from wash to measurement. The Cross time is the same as immediately after the power is turned on, and both SV6 and SV7 are OPEN.
- After the Cross time elapses, SV6 remains OPEN, SV7 becomes CLOSE, and only the sample that has passed through the sand filter tube of F1 is measured.

After the washing interval for DBL sand filter has passed, F2 is washed this time, and the filter leading to the flow cell is switched from F1 to F2. In this way, wash and measurement of F1 and F2 are always switched.

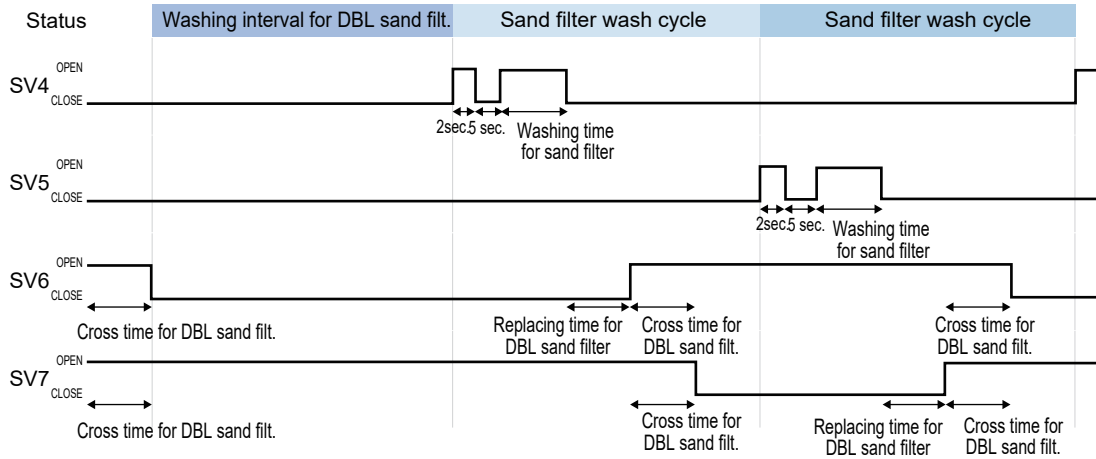

Customer Maintenance Parts List

RC800D Reagent Type Residual Chlorine Analyzer

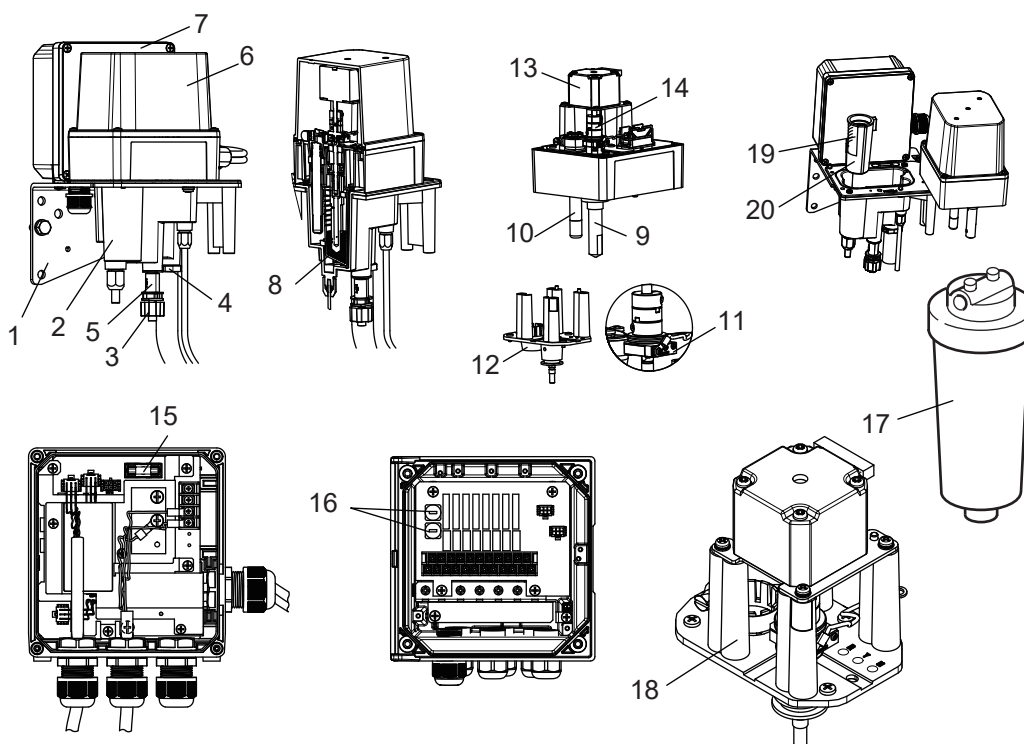

Item	Part No.	Qty	Description
1	K8005NG	1	Bracket
2	K8005MC	1	Tub
3	K8005LD	1	Cock Assy
4	K8005LJ	1	Nipple Assy
5	K8005LK	1	Connector Assy
6	K8005LE	1	Electrode Unit Cover
7	K8005LF	1	Smart Unit Cover
8	K9332ZJ	1	Glass Beads
9	K8005JC	1	Measurement Electrode
10	K8005UC	1	Reference Electrode for -C
	K8005UH	1	Reference Electrode for -F and -T
11	K9332SR	1	Rotating Contact
12	K8005LB	1	Driven Shaft Assembly
13	K8005LC	1	Motor
14	B1005AC	1	Coupling
15	A1633EF	1	Fuse (2.5A)
16	A1624EF	1	Fuse (3.15A)
17	L9862AY	1	Activated Charcoal Filter
18	K8005LG	1	Drive Unit
19	K9332KX	1	Beads Case
20	K8005NK	1	Beads Case Cover

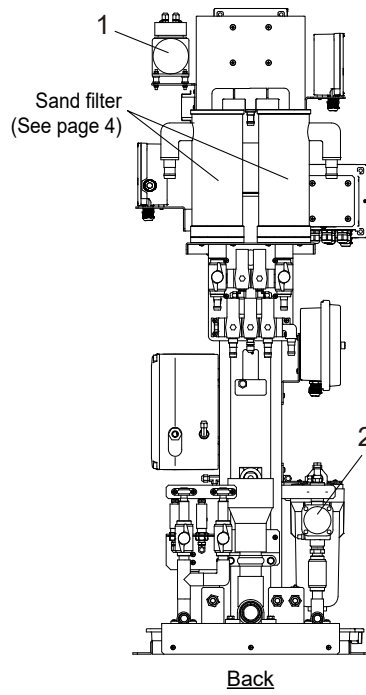
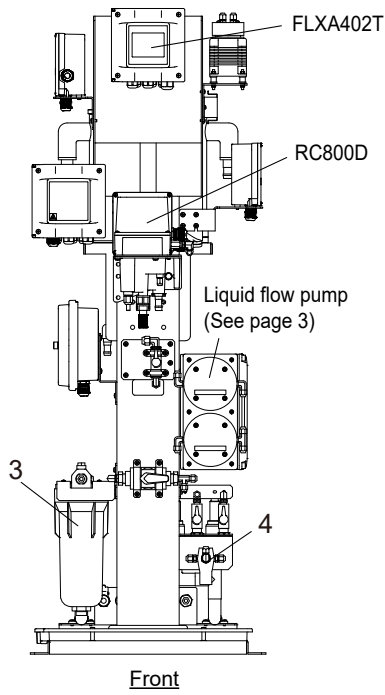

Item	Part No.	Qty	Description
1	—	1	Air Pump (Option)
	K9087XA	1	100 V AC power supply
	K9087XF	1	110 V AC power supply
	K9087XH	1	220 V AC power supply
2	K8004QG	1	Pressure Reducing Valve
3	K9726EG	1	Filter Assembly
	L9862AY	1	Filter Element
4	B1007ET	1	Solenoid Valve

LIQUID FLOW PUMP ASSEMBLY

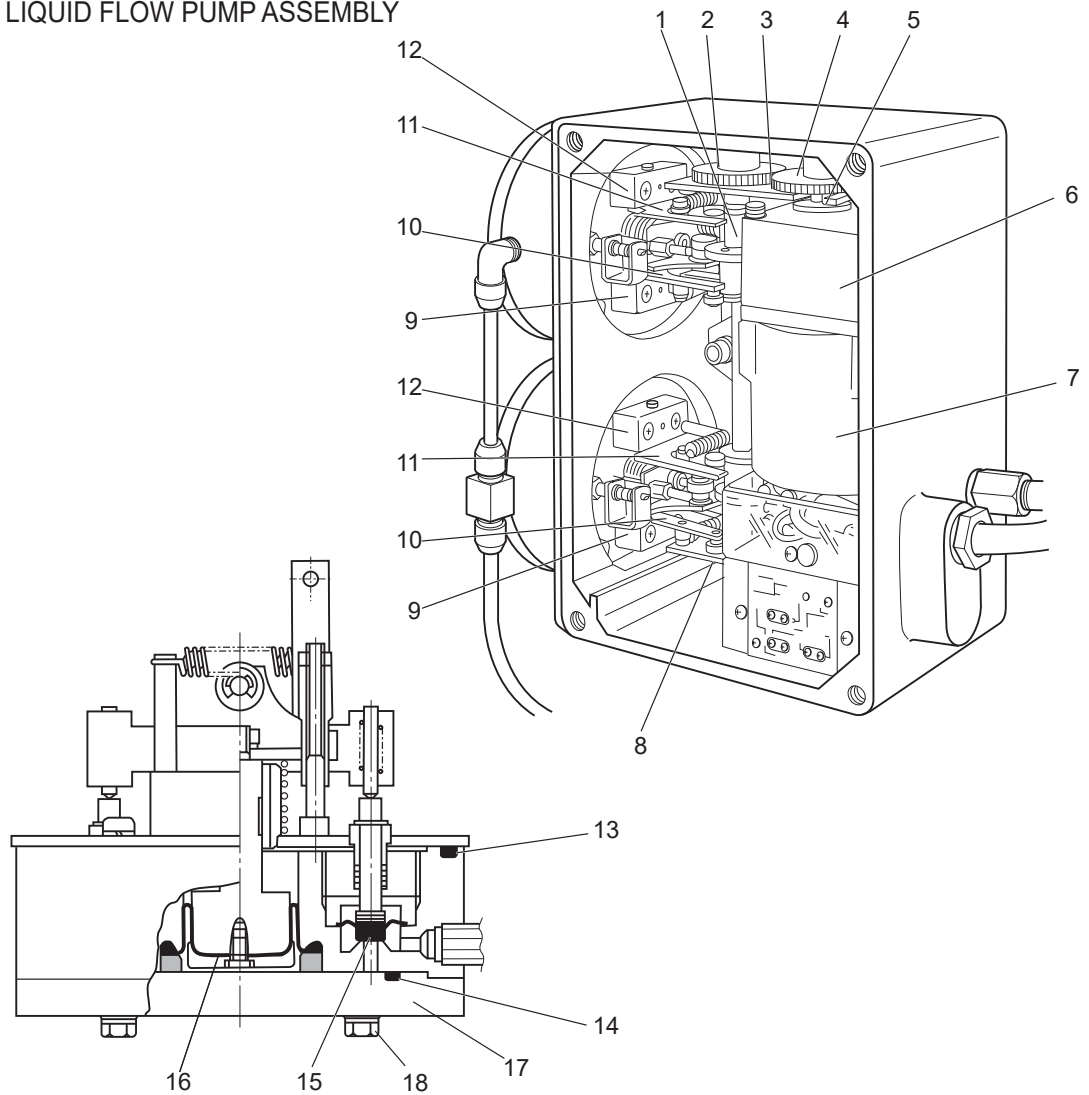

Item	Part No.	Qty	Description	Item	Part No.	Qty	Description
1	K9332HG	1	Cam Assembly	11	K9041JA	2	Lever Assembly
2	K9041BT	1	Gear	12	K9041JP	2	Block Assembly
3	K9041BK	1	Bracket Assembly	13	G9303AT	2	O-Ring
4	K9041DA	1	Gear	14	G9303AM	2	O-Ring
5	L9805GF	1	Bearing	15	K9041HC	4	Valve Sheet
6	K9041EK	1	Gear Head Assembly	16	L9819AA	1	Bellofram (for Reagent Pump)
7	K9041EL	1	Motor (For 100/110 V AC power supply)		K8004YY	1	Bellofram (for Sample Pump)
	K9041EM	1	Motor (For 220 V AC power supply)	17	K9041FU	1	Plate (for Reagent Pump)
8	K9041BP	1	Bracket Assembly		K9041FP	1	Plate (for Sample Pump)
9	K9041JU	2	Block Assembly	18	L9800EA	4	Screw (for each pump)
10	K9041JK	2	Lever Assembly				

Sand Filter

- For RC800D-2

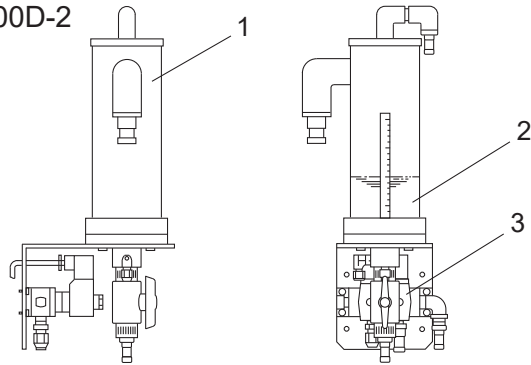

- For RC800D-3

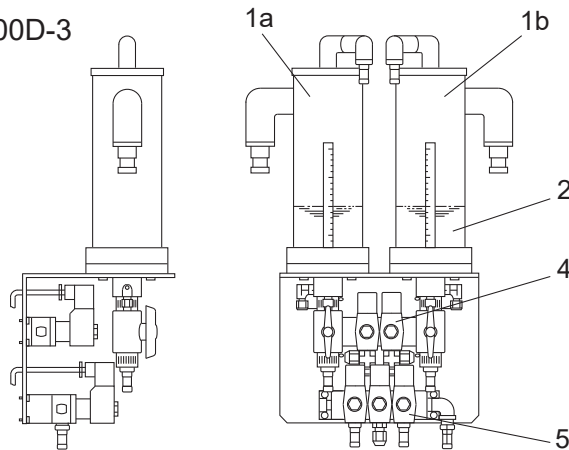

Item	Part No.	Qty	Description
1	K9332NH	1	Filter Assembly (for RC800D-2)
1a	K9332PG	1	Filter Assembly (for RC800D-3)
1b	K9332PH	1	Filter Assembly (for RC800D-3)
2	K9720FZ	1	Sand (1 liter)
3	—	1	Solenoid Valve (SV1, SV2 for RC800D-2)
	B1011ET		(For 100 V AC power supply)
	B1012ET		(For 110 V AC power supply)
	B1014ET		(For 220V AC power supply)
4	—	1	Solenoid Valve (SV3, SV4 for RC800D-3)
	B1015ET		(For 100 V AC power supply)
	B1016ET		(For 110 V AC power supply)
	B1018ET		(For 220 V AC power supply)
5	—	1	Solenoid Valve (SV1, SV2, SV5 for RC800D-3)
	B1019ET		(For 100 V AC power supply)
	B1020ET		(For 110 V AC power supply)
	B1022ET		(For 220 V AC power supply)

Customer Maintenance Parts List

Model RC401G Reagent Tank

EXA RC

● Model RC401G-A

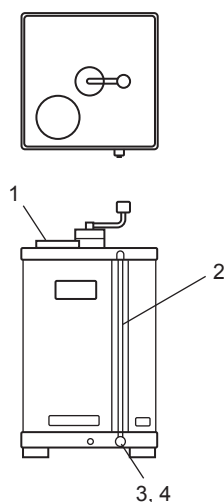

● Model RC401G-B

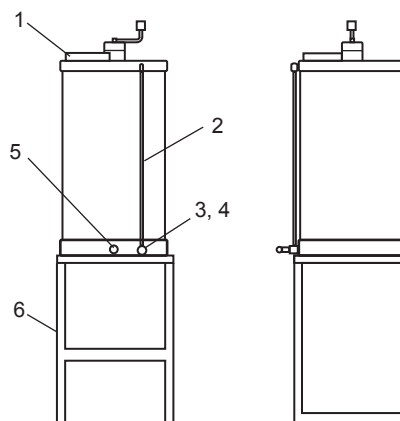

● Model RC401G-C

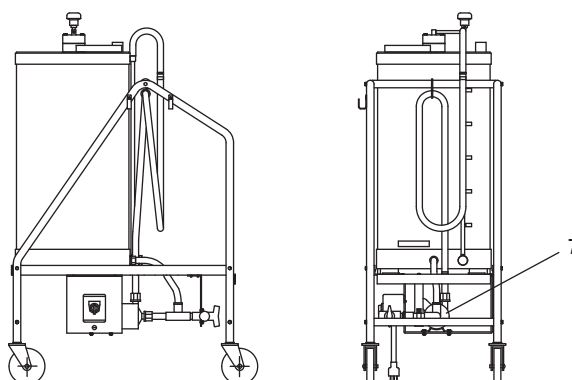

Item	Part No.	Qty	Description
1	K9041ZN	1	Cap
2	K9725GQ	1	Pipe
3	K9725GY	1	Plug
4	G9303NV	1	O-Ring
5	K9725HA	1	Needle Valve
6	K9332XA	1	Stand
7	L9869FJ	1	Pump *

* : Consult with Yokogawa for the product before April, 1999.

Revision Record

- Title : RC800D Reagent Type Residual Chlorine Sensor Unit
- Manual No. : IM 12F04B10-02EN

Dec. 2024/10th Edition

Revised CMPL 12F04B10-01EN (5th ed.)

Jan. 2024/9th Edition

Added sections.(Chapter 2)

July 2023/8th Edition

Added/changed description of measures against abnormal noise (Chapter 8)

Revised CMPL 12F04B10-01EN (5th ed.)

Feb. 2023/7th Edition

Notes on the model name and code table (page 1-6)

Revised CMPL (4th edition)

Mar. 2022/6th Edition

Changed the bellofram part number "L9819AB" to "K8004YY" (page 1-6, 1-7, 1-10)

Revised CMPL (3rd edition)

Mar. 2022/5th Edition

Added "CE" and accessory part numbers. (page 1-6)

Oct. 2021/4th Edition

Corrected the wiring diagrams. (pages 2-5 to 2-7)

Sep 2021/3rd Edition

Removed the suffix codes from RC800D and one spare part from the list (pages 1-6, 1-7)

Added the suffix code on FLXA402T (pages 2-5 to 2-7)

Revised CMPL (2nd edition)

July 2021/2nd Edition

Added notes. (page 4-2), Corrected figure. (page App.-1)

May 2021/1st Edition

Newly published.

Yokogawa Electric Corporation
2-9-32 Nakacho, Musashino-shi, Tokyo 180-8750, JAPAN
<http://www.yokogawa.com/>



